

# Riverside Energy Park

---

## Combined Heat and Power Assessment

---

VOLUME NUMBER:

**05**

PLANNING INSPECTORATE REFERENCE NUMBER:

**EN010093**

---

DOCUMENT REFERENCE:

**5.4**

---

November 2018 | Revision 0 | APFP Regulation 5(2)(q)

---

Planning Act 2008 | Infrastructure Planning (Applications: Prescribed Forms and Procedure) Regulations 2009

## Contents

- 1 Executive Summary ..... 1**
- 2 Introduction ..... 3**
  - 2.1 Background..... 3
  - 2.2 The Development Consent Order Process ..... 3
  - 2.3 The Applicant and Study Team ..... 3
  - 2.4 Purpose of this report..... 4
  - 2.5 Project Description ..... 5
  - 2.6 Structure of this report..... 6
- 3 Policy ..... 7**
  - 3.1 Introduction ..... 7
  - 3.2 National Planning Policy and Guidance ..... 7
  - 3.3 Regional Planning Policy, Strategies and Guidance ..... 9
  - 3.4 Local Planning Policy, Strategies and Guidance..... 12
  - 3.5 Summary..... 16
- 4 Legislative Requirements..... 18**
  - 4.1 CHP-Ready Guidance..... 18
  - 4.2 Energy Efficiency Directive ..... 18
  - 4.3 Carbon Intensity Floor..... 19
- 5 Technology Description ..... 22**
  - 5.1 Site Selection ..... 22
  - 5.2 Proposed Development..... 22
  - 5.3 The Energy Recovery Facility ..... 22
  - 5.4 Heat Supply System..... 23
- 6 Heat Demand Investigation ..... 26**
  - 6.2 Anaerobic Digestion Facility ..... 26
  - 6.3 Wider Heat Export Opportunities..... 27
  - 6.4 Prospective Developments ..... 36
  - 6.5 Heat Consumer Screening..... 38
  - 6.6 Heat Network Profile ..... 39
  - 6.7 Heat Network Design ..... 42
  - 6.8 Back-up Heat Source ..... 43
  - 6.9 Additional Heat Sources..... 44
  - 6.10 Indicative Pipe Route ..... 45

<b>7</b>	<b>Economic Assessment</b> .....	<b>47</b>
7.1	Fiscal Support .....	47
7.2	Technical Feasibility .....	48
7.3	Primary Energy Savings (PES) .....	49
7.4	Cost-benefit Assessment .....	49
<b>8</b>	<b>Energy Efficiency Measures</b> .....	<b>52</b>
8.1	Heat and Power Export .....	52
8.2	CHPQA Quality Index .....	52
<b>9</b>	<b>EA CHP-Ready Guidance</b> .....	<b>54</b>
9.2	CHP Envelope.....	54
9.3	CHP-Ready Assessment .....	55
9.4	CHP-Ready Provisions .....	56
<b>10</b>	<b>Conclusions</b> .....	<b>57</b>
10.1	Policy .....	57
10.2	Technical Solution.....	58
10.3	Heat Demand Investigation .....	58
10.4	Heat Network Profile .....	59
10.5	Economic Assessment.....	60
10.6	Energy Efficiency Measures.....	60

## Figures

Figure 1	– CBA methodology for type 14.5(a) and 14.5(b) installations .....	19
Figure 2	– REP Energy Recovery Facility schematic .....	23
Figure 3	– Local heat demand density, all sectors, National Heat Map .....	31
Figure 4	– Decentralised energy potential, London Heat Map.....	33
Figure 5	– Large heat consumers, UK CHP Development Map .....	35
Figure 6	– Projected heat network profile showing daily and seasonal variation .....	40
Figure 7	– Heat load duration curve .....	41
Figure 8	– Graphical representation of CHP envelope for REP network .....	55

## Tables

Table 1	– GHG calculator model results.....	21
Table 2	– Anaerobic Digestion facility heat demand.....	26
Table 3	– Heat consumption in London .....	27
Table 4	– Cooling consumption in London .....	28
Table 5	– Heat demand within 10 km search radius.....	29

Table 6 – Large heat consumers ..... 34  
Table 7 – Proposed developments as part of Thamesmead regeneration ..... 37  
Table 8 – Preferred DH network parameters ..... 40  
Table 9 – District heating network typical design criteria ..... 43  
Table 10 – Heat and power export ..... 52  
Table 11 – Heat and power export ..... 53

**Appendices**

Appendix A Modelled Residual Waste Composition for CIF Assessment  
Appendix B Site Layout  
Appendix C Indicative ERF Heat and Mass Balance  
Appendix D Potential Existing Heat Consumers  
Appendix E Location of Potential Heat Consumers  
Appendix F Indicative Pipe Route  
Appendix G Cost-Benefit Assessment Inputs and Key Outputs  
Appendix H CHP-Ready Application

This page is intentionally blank

## 1 Executive Summary

- 1.1.1 The Overarching National Policy Statement for Energy (NPS EN-1) (part 4.6) makes clear the policy preference for waste energy recovery infrastructure to provide Combined Heat and Power (CHP). Paragraph 4.6.8 establishes the test to be met by Nationally Significant Infrastructure Projects such as Riverside Energy Park (REP).
- 1.1.2 *“Utilisation of useful heat that displaces conventional heat generation from fossil fuel sources is to be encouraged where, as will often be the case, it is more efficient than the alternative electricity/heat generation mix. To encourage proper consideration of CHP, substantial additional positive weight should therefore be given by the IPC to applications incorporating CHP. ...”*
- 1.1.3 The National Policy Statement for Renewable Energy Infrastructure (NPS EN-3) confirms that the decision-maker should be satisfied that appropriate evidence has been submitted to demonstrate that CHP is included, or that the opportunities have been fully explored (paragraph 2.5.27).
- 1.1.4 As such, Cory Environmental Holdings Limited (trading as Cory Riverside Energy (Cory)) (the Applicant) has considered the opportunities for heat connection specifically for REP.
- 1.1.5 REP is an integrated Energy Park; the principal elements of REP comprise complementary energy generating development and an associated Electrical Connection (together referred to as the ‘Proposed Development’).
- 1.1.6 REP therefore responds directly to the outcomes sought through the National Policy Statements EN-1 and EN-3 by being designed at the outset as CHP Enabled. A CHP Enabled plant is one which is fully capable of exporting heat, with all required on site infrastructure in place.
- 1.1.7 The Adopted and Draft London Plan(s) and LBB’s Sustainable Design and Construction SPD also require developments to examine the opportunity to extend on site CHP systems beyond application sites to adjacent sites and follow the hierarchy of energy systems. The Mayor of London has identified Heat Network Priority Areas across London. These areas identify where in London the heat density is sufficient for heat networks to provide a competitive solution for supplying heat to buildings and consumers. REP falls within one of the identified Heat Network Priority Areas.
- 1.1.8 The Applicant has worked closely with London Borough of Bexley (LBB) and the Greater London Authority in preparing the LBB Bexley Energy Masterplan (EMP) (2015) to ensure that the benefits of any potential CHP opportunities are maximised including wider opportunities with heat export by considering a District Heating (DH) scheme.
- 1.1.9 The Environment Agency (EA) requires Environmental Permit applications to demonstrate Best Available Techniques (BAT) for a number of criteria, including

energy efficiency. One of the principal ways of improving energy efficiency is through the use of CHP.

- 1.1.10 The EA considers CHP Enabled plants as BAT for energy efficiency in circumstances where there are technically and economically viable opportunities for the supply of heat from the outset. This CHP Study has been carried out to demonstrate that REP is designed to be ready, with minimum modification, to supply additional heat in the future. The Proposed Development therefore exceeds the requirement for 'CHP ready' and will be CHP Enabled (i.e. developed with on site infrastructure already in place).
- 1.1.11 Furthermore, this report demonstrates some of the benefits of operating REP in CHP mode. REP would exceed the high-efficiency cogeneration threshold for delivering primary energy savings when operating in fully condensing (electricity only) mode. The inclusion of heat export further increases this efficiency, increasing the primary energy savings achieved by REP. Consequently, the Proposed Development would qualify as a high efficiency cogeneration operation when operating in CHP mode, exceeding the Primary Energy Savings threshold, and in turn meet the GLA's Carbon Intensity Floor target in that mode.
- 1.1.12 In summary, the Proposed Development is located within a Heat Network Priority Area, is CHP Enabled and includes all the on-site infrastructure necessary to connect to a heat distribution network. The Applicant continues to actively engage with LBB and other key relevant stakeholders to deliver this network, and considers this element of the Proposed Development carries the opportunity for significant and direct societal benefits in the local area.

## 2 Introduction

### 2.1 Background

- 2.1.1 Cory Environmental Holdings Limited (trading as Cory Riverside Energy (Cory)) (the Applicant) is applying to the Secretary of State under the Planning Act 2008 (PA 2008) for powers to construct, operate and maintain an integrated Energy Park, to be known as Riverside Energy Park (REP). The principal elements of REP comprise complementary energy generating development and an associated Electrical Connection (together referred to as the 'Proposed Development'). As the generating capacity of REP will be in excess of 50 MWe, it is classified as a Nationally Significant Infrastructure Project (NSIP) under Sections 14 and 15 of the PA 2008 and therefore requires a Development Consent Order (DCO) to authorise its construction and operation.
- 2.1.2 REP would be constructed on land immediately adjacent to Cory's existing Energy Recovery Facility (ERF) (referred to as Riverside Resource Recovery Facility (RRRF)) situated at Norman Road in Belvedere, within the London Borough of Bexley (LBB). The underground Electrical Connection would run from the REP site and terminate at the Littlebrook substation in Dartford.
- 2.1.3 Fichtner Consulting Engineers Limited (Fichtner) has been commissioned by the Applicant to prepare a Combined Heat and Power (CHP) Study (herein 'this report') to assess the feasibility of supplying heat from REP to local heat consumers. This builds on the existing work which has been undertaken by the Applicant to identify potential opportunities and benefits to the local community from CHP including work which has been undertaken with key local authority and housing developer stakeholders.

### 2.2 The Development Consent Order Process

- 2.2.1 Cory must submit a DCO application to the Planning Inspectorate (PINS) who will first decide whether to accept the application. If accepted, PINS will examine the application in accordance with the relevant National Policy Statements (NPSs) which outline the need for energy infrastructure and the issues to be considered in applications. The relevant NPSs include: NPS EN-1 (Overarching Energy Policy), NPS EN-3 (Renewable Energy Supply from Waste) and NPS EN-5 (Electricity Networks Infrastructure).
- 2.2.2 Following the examination, PINS will make a recommendation to the relevant Secretary of State (SoS) and, should the SoS approve the application, the DCO will be made authorising the construction, commissioning and operation of REP.

### 2.3 The Applicant and Study Team

- 2.3.1 Cory Environmental Holdings Limited is registered in England (Company Number 05360864) and is the Applicant for the Proposed Development. The Applicant's registered address is 2 Coldbath Square, London, United Kingdom, EC1R 5HL.



- 2.3.2 The Applicant is a leading recycling, energy recovery and resource management company, with an extensive river logistics network in London. The Applicant secured consent for, constructed and now operates the existing RRRF adjacent to the Proposed Development.
- 2.3.3 The Applicant is now progressing these plans for the Proposed Development to maximise the use of its existing infrastructure and to further meet the needs for resource recovery and energy generation in UK and London.
- 2.3.4 Further information on REP is provided on the dedicated project website at <http://www.riversideenergypark.com>. Preparation of this report has been undertaken by Fichtner and Peter Brett Associates LLP.

## **2.4 Purpose of this report**

- 2.4.1 The purpose of this report is to demonstrate the CHP opportunity, benefits and feasibility of supplying heat from REP to local heat consumers. This report responds to Section 4.6 of NPS EN-1 which requires applications for thermal generating stations, such as the proposed ERF at REP, to consider CHP. It also highlights the work undertaken by the Applicant in exploring potential CHP opportunities and benefits, and how the Applicant has exceeded the policy requirements of NPS EN-1. As such the principal objectives of this report are as follows:
- i. Prepare a CHP Study demonstrating exceedance of the requirements of the Environment Agency (EA) CHP-Ready Guidance, to support the DCO application;
  - ii. Provide a technical description of REP and heat export infrastructure;
  - iii. Identify heat export opportunities local to REP, and assess feasibility for connection to a DH network;
  - iv. Highlighting the work undertaken by the Applicant in exploring potential CHP opportunities and benefits with stakeholders, including community schemes;
  - v. Assess the feasibility of connecting additional heat sources to the network to maximise benefits of the scheme in terms of added resilience of heat supply and overall heat opportunity;
  - vi. Calculate heat demand and profiles focusing on viable CHP opportunities, accounting for consumer diversity and seasonal variation;
  - vii. Carry out an economic appraisal of the preferred solution in accordance with the requirements of the EA's guidance on cost-benefit assessment (CBA) for combustion installations;
  - viii. Calculate relevant energy efficiency measures to demonstrate legislative compliance; and

- ix. Produce a CHP-Ready Assessment as required under the EA CHP-Ready guidance, including a clear statement on Best Available Technique (BAT), CHP envelope and the CHP-Ready Assessment form.

2.4.2 This report has also been prepared to support the DCO application for REP.

## 2.5 Project Description

2.5.1 The Proposed Development comprises REP, together with an associated Electrical Connection (together known as the 'Proposed Development'). These are described in turn, together with the anticipated REP operations, below.

2.5.2 Chapter 3 of the Environmental Statement (ES) (**Document Reference 6.1**) provides further details of the Proposed Development.

### REP

2.5.3 REP would be constructed on land immediately adjacent to Cory's existing RRRF, within the LBB and would complement the operation of the existing facility. It would comprise an integrated range of technologies including: waste energy recovery, anaerobic digestion, solar panels and battery storage. The main elements of REP would be as follows:

- Energy Recovery Facility (ERF): to provide thermal treatment of Commercial and Industrial (C&I) residual (non-recyclable) waste with the potential for treatment of (non-recyclable) Municipal Solid Waste (MSW);
- Anaerobic Digestion facility: to process food and green waste. Outputs from the Anaerobic Digestion facility would be transferred off-site for use in the agricultural sector as fertiliser or as an alternative, where appropriate, used as a fuel in the ERF to generate electricity;
- Solar Photovoltaic Installation: to generate electricity. Installed across a wide extent of the roof of the Main REP building;
- Battery Storage: to store and supply additional power to the local distribution network at times of peak electrical demand. This facility would be integrated into the Main REP building; and
- On Site Combined Heat and Power (CHP) Infrastructure: to provide an opportunity for local DH for nearby residential developments and businesses. REP would be CHP Enabled with necessary on site infrastructure included within the REP site.

### Electrical Connection

2.5.4 REP would be connected to the electricity distribution network via a new 132 kilo-volt (kV) underground electricity cable connection. The route options for the Electrical Connection are shown in the Works Plans (**Document Reference 2.4**).

2.5.5 In consultation with UK Power Networks (UKPN), the Applicant is considering Electrical Connection route options to connect to the existing National Grid Littlebrook substation located south east of the REP site, in Dartford. The route options are located within the LBB and Dartford Borough Council (DBC), and would run from a new substation proposed to be constructed within the REP site.

## 2.6 Structure of this report

2.6.1 This report is set out in the following format:

- Section 3: Policy;
- Section 4: Legislative Requirements;
- Section 5: Technology Description;
- Section 6: Heat Demand Investigation;
- Section 7: Economic Assessment;
- Section 8: Energy Efficiency Measures;
- Section 9: EA CHP-Ready Guidance; and
- Section 10: Conclusions.

2.6.2 A full glossary of defined terms and abbreviations is presented in the Project Glossary (**Document Reference 1.6**).

## 3 Policy

### 3.1 Introduction

- 3.1.1 This section demonstrates how REP meets the clear preference for plant that provides CHP which is emphasised in relevant national and local policy requirements relating to the provision of CHP. A detailed description of all planning policy and guidance for the Proposed Development and how it is compliant with these requirements can be found in the Planning Statement (**Document Reference 7.1**). Below sets out the key policy requirements which the Applicant has considered the opportunities for heat connection against.
- 3.1.2 The wider benefits including provision of CHP to the local community is further considered within the Project and its Benefits document (**Document Reference 7.2**).

### 3.2 National Planning Policy and Guidance

#### National Planning Statements

- 3.2.1 In accordance with the Planning Act 2008, the Secretary of State is required to determine an application for an order granting development consent (DCO) for an energy NSIP in accordance with the Overarching National Policy Statement for Energy (NPS EN-1) and the relevant technology-specific National Policy Statement for the Application (National Planning Statement – Renewable Energy Infrastructure (NPS EN-3) in the case for the Proposed Development).
- 3.2.2 NPS EN-1 outlines the Government’s policy for delivery of major energy infrastructure in England and Wales.
- 3.2.3 Part 4.6 ‘Consideration of Combined Heat and Power (CHP)’ of NPS EN-1 makes clear the preference or requirement for a development to consider and/or implement CHP.
- 3.2.4 Paragraph 4.6.7 states “*developers should consider the opportunities for CHP from the very earliest point and it should be adopted as a criterion when considering locations for a project*”. From an early stage in the development of the Proposed Development, the Applicant has considered opportunities for CHP. The Proposed Development will be CHP Enabled from the outset, but the Applicant has also identified wider opportunities to maximise the benefits associated with heat export by considering a DH scheme.
- 3.2.5 The importance of early liaison and consultation is also emphasised in Paragraph 4.6.7, which states that “*...applicants should not only consult those potential customers they have identified themselves but also bodies such as the Homes and Communities Agency (HCA), Local Enterprise Partnerships (LEPs) and Local Authorities and obtain their advice on opportunities for CHP*”. The following sections of this report outline the levels of engagement the Applicant has had with local developers, local planning authorities (LBB and Royal

Borough of Greenwich (RBG)) and the Greater London Authority (GLA) in regards to the opportunities for CHP.

- 3.2.6 Furthermore, paragraph 4.6.8 establishes the test to be met by NSIPs, such as the Proposed Development: *“Utilisation of useful heat that displaces conventional heat generation from fossil fuel sources is to be encouraged where, as will often be the case, it is more efficient than the alternative electricity/heat generation mix. To encourage proper consideration of CHP, substantial additional positive weight should therefore be given by the IPC to applications incorporating CHP”*.
- 3.2.7 Paragraph 4.6.9 also states that the Applicant should *“explain how the development can be both ready to provide CHP in the future and also be Carbon Capture Ready or set out any constraints”*.
- 3.2.8 The NPS EN-3 (Renewable Energy Infrastructure) applies to nationally significant energy from biomass/waste infrastructure in England and Wales with at least 50 MW electrical generating capacity. NPS EN-3 states that new developments should consider CHP as part of its application, or demonstrate that CHP has been considered, and the Secretary of State can seek further information should this not be provided. Section 2.5 of NPS EN-3 states that biomass/Energy from Waste generating stations can be configured to produce CHP. As such, this report satisfies NPS EN-3 requirements as being appropriate evidence submitted to demonstrate the opportunities for CHP have been explored.

### National Planning Policy for Waste

- 3.2.9 The National Planning Policy for Waste (NPPW) was published in October 2014 and sets out the Government’s ambition to develop a more sustainable and efficient approach to resource use and management. Critically, the NPPW recognises the positive role that planning can have to deliver *“sustainable development and resource efficiency, including; the provision of modern infrastructure, local employment opportunities and wider climate change benefits by driving waste management up the waste hierarchy”* (page 3). Not least, these benefits are to be achieved through ensuring that waste management is considered alongside other spatial planning concerns and recognising the positive contribution that waste management can make to the development of sustainable communities (page 3).

### National Planning Policy Framework

- 3.2.10 The revised National Planning Policy Framework (NPPF) was published in July 2018 and retains the “presumption in favour of sustainable development”.
- 3.2.11 Paragraphs 148-154 of the NPPF explain that planning plays a key role in helping shape places to secure radical reductions in greenhouse gas emissions, and in supporting the delivery of renewable and low carbon energy and

associated infrastructure. This is central to the economic, social and environmental dimensions of sustainable development.

3.2.12 Local planning authorities are advised to adopt proactive strategies to mitigate and adapt to climate change, and local planning authorities should:

- recognise the responsibility on all communities to contribute to energy generation from renewable or low carbon sources; and
- when determining planning applications, not require applicants for renewable and low carbon development to demonstrate the overall need for renewable or low carbon energy and approve the application if its impacts are (or can be made) acceptable (page 44-45).

### 3.3 Regional Planning Policy, Strategies and Guidance

#### Adopted London Plan

3.3.1 The London Plan, revised in March 2016, sets the overarching strategic plan for development in London over the next 20 to 25 years. This Plan contains a number of adopted policies in relation to energy and more specifically the provision of CHP that are applicable to the Proposed Development.

3.3.2 Chapter 5 of the London Plan, presents the strategic policy for London's response to climate change. Paragraph 5.9 identifies that delivering a city leading in improving the environment locally and globally will require a move to more sustainable energy sources, to be achieved through supporting "*the development of decentralised energy systems, including the use of low carbon and renewable energy and the greater utilisation of energy generated from waste*" (page 178). Reflecting policy objectives of the National Policy Statements, this approach is intended to bring energy resilience and security to London.

3.3.3 Policy 5.2 – Minimising Carbon Dioxide Emissions requires "*development proposals to make the fullest contribution to minimising carbon dioxide emissions in accordance with the energy hierarchy*" (page 180). The Proposed Development will contribute to minimising carbon dioxide emissions through sustainable use of energy in accordance with the hierarchy. The Proposed Development will strongly support the second step of the hierarchy to supply energy efficiently by prioritising/providing a local decentralised energy system.

3.3.4 Policy 5.5 – Decentralised Energy Networks, focusses on energy supply, stating an expectation that 25% of the heat and power used in London will be generated through the use of localised, decentralised energy systems by 2025. Policy 5.6 – Decentralised Energy in Development Proposals and Policy 5.7 – Renewable Energy, seek to increase the proportion of energy generated from renewable sources, specifically CHP systems. The Proposed Development strongly supports the requirements set out in these Policies. REP will be CHP Enabled with necessary on-site infrastructure included in the proposals, which therefore supports the overarching objectives for these policies. Furthermore, this report

demonstrates potential opportunities to extend the system beyond the REP site boundary and provide an opportunity for local DH for nearby residential developments at Thamesmead.

- 3.3.5 As such, the Proposed Development responds directly to the identified challenges in the London Plan, providing a local source of renewable/low carbon energy recovered from London's residual waste, and does so whilst meeting the criteria for new waste management development set out within Policy 5.17 – Waste Capacity.

### **London Environment Strategy**

- 3.3.6 The Mayor published the London Environment Strategy in May 2018. The Strategy sets out a range of actions to improve the environment, including specific policies and targets for energy and waste. The Mayor is required to prepare a London Environment Strategy by the Greater London Authority Act 1999, as amended, under changes made by the Localism Act 2011.

- 3.3.7 Chapter 6 presents the strategic policy, objectives and proposals for climate change mitigation and energy. The Mayor's commitment to London becoming a zero carbon city by 2050 is made clear throughout this chapter. Objective 6.2 focuses on the Mayor's aspirations regarding the development of clean and smart integrated energy systems that utilise local and renewable energy resources. The Proposed Development supports Objective 6.2 and subsequent policies because it will help to increase the delivery of decentralised low carbon energy in London through the use of local and renewable energy resources. The Proposed Development will produce a range of decentralised energy, including electricity from the solar PV panels and ERF, as well as providing the opportunity for local DH for nearby residents and businesses. Additionally, the battery storage will store and supply additional power to the local distribution network at times of peak electrical demand. As such, the Proposed Development is helping support London's transition to becoming zero carbon by 2050 through the provision of suitable energy infrastructure.

### **Adopted London's Wasted Resource: The Mayor's Municipal Waste Management Strategy**

- 3.3.8 The Mayor's Municipal Waste Management Strategy (MMWMS) was published in November 2011 and sets policies for the management of London's municipal waste up to 2031. The MMWMS recognises that London's non-recycled municipal waste, used as low carbon fuel, will play an important role in delivering the Mayor's decentralised energy targets. The Proposed Development will support the policies set in MMWMS, specifically; Policy 2 – Reducing the Climate Change Impact of London's Municipal Waste Management and Policy 5 – Stimulating the Development of New Municipal Waste Management Infrastructure in London, particularly low-carbon technologies.

- 3.3.9 As noted in Section 5.2 of this report, the Proposed Development would include an Anaerobic Digestion Facility which would accept green and food waste.

Anaerobic digestion has been recognised as one of the best methods for food recycling and as such will help contribute towards the zero biodegradable or recyclable waste being sent to landfills target and provide an ‘in borough’ Anaerobic Digestion solution for the London Borough of Bexley preventing carbon intensive mileage of existing ‘out of borough’ facilities. Outputs from the Anaerobic Digestion facility may also be used as a fuel in the ERF to generate electricity or transferred off-site for use as a fertiliser in the agricultural sector.

3.3.10 Furthermore, despite the expected improvements in the prevention, re-use and recycling of waste, there will remain residual waste that should be diverted from landfill. The Proposed Development will be a suitable alternative to help treat London’s waste remaining after recycling, helping to ensure that less waste is sent to landfill or shipped overseas. Therefore, it is important to note, that the ERF will support the drive to move waste further up the waste hierarchy and work alongside the Mayor’s recycling aspirations. In addition, the Proposed Development will contribute towards generating renewable/low-carbon energy in London from the remaining waste not suitable for recycling, and recover secondary materials post-combustion, both important elements of the Circular Economy.

### Draft London Plan

3.3.11 A Draft London Plan has been prepared, which once adopted, will supersede the existing policies within the London Plan (2016). The Draft New London Plan showing Minor Suggested Changes following updates to the Consultation Draft Plan, was published on 13<sup>th</sup> August 2018.

3.3.12 Chapter 9 presents the strategic policy for sustainable infrastructure. The Mayor’s commitment to London becoming a zero carbon city is made clear, not least at paragraph 9.2.1. Paragraph 9.2.10 encourages the use of energy strategies, identifying the potential to reduce carbon dioxide emissions through the use of zero or low-emission decentralised energy supply, such as the Proposed Development.

3.3.13 Draft Policy SI3 – Energy Infrastructure seeks energy masterplans to be developed for large-scale development locations, which should identify, inter alia, possible opportunities to utilise energy from waste (SI3B/3) and land for energy centres and/or energy storage (SI3B/7). Thus, the Proposed Development strongly supports the requirements outlined in Draft Policy SI3 and should be considered a suitable site for necessary energy infrastructure. It demonstrates strong potential to be a multi-technology energy centre which will provide a renewable/low carbon energy supply and have a positive carbon outcome, including the use of CHP. This Draft Policy also emphasises that “*developers should engage at an early stage with relevant energy companies and companies to establish the future energy requirements and infrastructure arising from large-scale development proposals*” and that where developments



are proposed within Heat Network Priority Areas<sup>1</sup>, such as the Proposed Development, but are beyond existing heat networks, the heating systems should be designed to facilitate future connection (page 123-124).

3.3.14 Draft Policy SI8C – Waste capacity and net waste self-sufficiency, encourages delivery of combined heat and power and combined cooling heat and power (SI8C/4). Within the London Environment Strategy, the Mayor commits to work to increase delivery of decentralised energy in London, including large scale decentralised and low carbon energy projects; potentially having “*a more direct role in the delivery of heat networks, significantly increasing the rate of their development in London.*” (Policy 6.2.1 and page 263).

### 3.4 Local Planning Policy, Strategies and Guidance

3.4.1 The Proposed Development is situated within the jurisdictions of LBB and DBC. Therefore, the relevant local policy requirements and guidance which relates to the provision of CHP includes policies set by LBB and DBC, as well as mineral and waste policies set by Kent County Council (KCC). This sub-section of the report also considers policies set by RBG, as some of the heat export opportunities discussed in the following sections of this report are at proposed sites in the RBG administrative area.

#### LBB – Core Strategy

3.4.2 The Core Strategy, adopted by LBB in February 2012, sets out the spatial strategy for the Borough over the next 15 years to meet the challenges of a changing environment. The main policies within the Core Strategy, that relate to the provision of CHP, are Policy CS01 – Achieving Sustainable Development and Policy CS08 – Adapting to and Mitigating the Effects of Climate Change.

3.4.3 Policy CS01 outlines how LBB aims to achieve ‘sustainable development’ in line with Bexley’s Sustainable Community Strategy. This policy requires developers to address the sustainable development principles set out in the policy, including; “*adapting to and mitigating the effects of climate change...and maximising the effective and efficient use of natural and physical resources...including energy*”. The Proposed Development supports Policy CS01 by providing suitable energy infrastructure that helps move away from using high carbon natural gas to an energy system being fuelled more from renewable energy and heat.

3.4.4 Policy CS08 requires “*all developments to contribute to the delivery of sustainable development by planning for, adapting to and mitigating the impacts of climate change by reducing the carbon emissions related to the construction and operation of the development*”. This policy notes that LBB will achieve this aim by applying the requirements set in national and regional planning guidance, notably, the London Plan and in particular the Mayor’s environmental policies, including “*reducing CO2 emissions, the Mayor’s energy hierarchy,*

---

<sup>1</sup> The Mayor has identified Heat Network Priority Areas. These areas identify where in London the heat density is sufficient for heat networks to provide a competitive solution for supplying heat to buildings and consumers.

*integrating energy efficiency, decentralised energy (in particular district heating where appropriate), site wide communal heat networks supported by CHP, adopting on-site renewable energy technologies” (page 60). As such, this will comprise:*

- investigating opportunities within the Borough for the location of zero carbon developments, prioritising those areas being investigated for decentralised energy networks.

3.4.5 Through the design principles of the Proposed Development and the findings in this report, it is evident that the Proposed Development strongly supports the requirements set out in Policy CS08. This policy identifies a need for climate change initiatives, such as the provision of decentralised energy sources, of which this need will be met by the Proposed Development. The Proposed Development will be CHP Enabled and will have on-site infrastructure to provide the opportunity for local DH for nearby residential and commercial developments (see Section 9 of this report). The provision of CHP not only accords with Policy CS08 but also the Mayor’s energy hierarchy, by helping to further reduce carbon dioxide emissions in the Borough through the use of decentralised energy. As such, the Proposed Development demonstrates a strong potential to provide a renewable/low carbon energy supply and have a positive carbon outcome.

### **LBB – Growth Strategy**

3.4.6 The Bexley Growth Strategy was adopted in 2017 and details LBB’s proposals to manage housing and economic growth, and associated supporting infrastructure. The Strategy isn’t a planning policy document as such; however, it is intended to underpin future planning policy and should inform development and investment decisions in the Borough. The Strategy states that LBB will seek to use modern technology to identify cost effective utility solutions, such as existing heat sources (notably the RRRF) to supply market competitive, low carbon energy to new developments and existing properties.

### **LBB – Energy Masterplan**

3.4.7 The Bexley Energy Masterplan (EMP) was published in 2015 and produced by consultants Ramboll. The EMP sets out a framework for future energy supply options to support the Core Strategy’s sustainability targets and study is centred on the RRRF. The Applicant has consulted extensively with LBB and GLA in preparing the EMP to ensure that benefits of any potential CHP opportunities are maximised.

3.4.8 Chapter 4 of the EMP identifies RRRF as the primary heat source, processing 670,000 tonnes of London’s waste per annum and generating a gross power output of over 60 MWe. The EMP recognises that the facility has the necessary infrastructure for heat off-take to be provided without substantial alteration and estimates that around 28.6 MTh of heat is available for export to a heat network.

3.4.9 The EMP identifies an opportunity for the RRRF to supply heat to the Peabody Thamesmead housing estate, Belvedere Growth Area and Yarnton Way employment land developments as part of a new district heat network. As such, the Applicant is engaged in discussions with LBB, RBG and Peabody Estates regarding heat export opportunities (see Section 6).

#### **LBB – Thamesmead and Abbey Wood (SPD)**

3.4.10 The Thamesmead and Abbey Wood SPD, adopted in December 2009, sets out the spatial vision for the area and provides general principles outlined in the current planning policy framework. A key guidance statement, applicable to the Proposed Development, is TSD1 – High Quality Development in Thamesmead. TSD1 supports the consideration of current supply and future demand for energy, in relation to opportunities for district heat networks and low carbon technologies. The SPD notes that new developments should be connected to a heat network if it is feasible and investigate the incorporation of renewable energy technologies. As discussed in other sections of this report, seven prospective residential and commercial developments in Thamesmead have been identified as potentially feasible for the inclusion in a district heat network, which in turn supports the requirements set out in this SPD.

#### **LBB – Sustainable Design and Construction SPD**

3.4.11 LBB adopted its Sustainable Design and Construction SPD in October 2007. This SPD provides detailed advice on the creation of environmentally friendly and sustainable developments within the Borough. The main guidance notes relating to the provision of CHP are Guidance 15, 16 and 19.

- Guidance 15 notes that developers are encouraged to provide 20% of the energy needs of a development from renewable sources in line with the Draft London Plan's energy targets;
- Guidance 16 explains how LBB requires all development to follow the principles of the energy hierarchy, as defined in Green Light to Clean Power: The Mayor's Energy Strategy; and
- Guidance 19 sets out the approach developers should take when providing renewable energy technologies.

3.4.12 The design principles of the Proposed Development comply with the guidance set in this SPD. The Proposed Development follows the principles of the energy hierarchy, particularly 'be green' and 'be clean', by installing an array of renewable energy technologies on-site which will provide a low carbon energy supply.

#### **LBB – Draft Local Plan**

3.4.13 LBB is in the process of updating the Local Plan to provide the strategy for the Borough up to 2040. Between November 2017 and August 2018, LBB carried out its preparations of Local Plan preferred approach to policies, with a view to

consulting on the preferred approach from August 2018 (although this has not commenced yet). Therefore, the emerging Local Plan is not available for consideration at this stage, and the existing Core Strategy and associated documents outline the key planning policies and considerations.

### **DBC – Core Strategy**

3.4.14 DBC adopted its Core Strategy in September 2011. The Core Strategy sets out the long-term spatial strategy for the Borough to 2026.

3.4.15 The Core Strategy contains one key policy which relates to the provision of CHP, namely, Policy CS 23 – Minimising Carbon Emissions. Policy CS 23 addresses DBC's requirements to minimise carbon emissions through the provision of energy efficiency measures and the use of renewable energy. The policy states that developments listed in this policy, subject to feasibility, provide low/zero carbon CHP either on or off-site and where supply is provided in the later phases of development, infrastructure to enable future connection should be provided in the early phases. Although this policy focuses on sites stated in this policy, it is demonstrated that the Proposed Development shows compliance with the ethos of Policy CS 23. Notably, the Proposed Development will be CHP Enabled with necessary on-site infrastructure included in the proposals to provide the opportunity for local DH for nearby residential and commercial developments (parts d and e of this policy) and the findings of this report will demonstrate the feasibility of supplying heat from the Proposed Development to local heat consumers offsite (part e of this policy).

3.4.16 As such, the Proposed Development, supports the requirements, in relation to the provision of CHP, in DBC's Core Strategy.

### **KCC – Minerals and Waste Local Plan**

3.4.17 The Kent Minerals and Waste Local Plan (MWLP), adopted in July 2016, sets out the vision and strategy for managing waste and the provision of waste infrastructure within the County until 2030.

3.4.18 The Proposed Development supports some of the strategic objectives set out in the MWLP, notably objective(s) 2, 11, 12 and 13. These objectives focus on ensuring new waste developments contribute towards the minimisation, and adaptation to, of the effects of climate change, which includes supporting the delivery of renewable and low carbon energy and associated infrastructure and promoting the movement of waste up the Waste Hierarchy. The Proposed Development will be a suitable alternative to help treat London's waste remaining after recycling, helping to ensure that less waste is sent to landfill or shipped overseas. In addition, the Proposed Development will contribute towards generating renewable/low-carbon energy in London from the remaining waste not suitable for recycling, and recover secondary materials post-combustion.

3.4.19 Furthermore, the Proposed Development also supports Policy CSW7 – Waste Management for Non-hazardous Waste. Policy CSW7 states how “*sites for anaerobic digestion, composting, Energy from Waste, mechanical biological treatment and other energy and value recovery technologies...will be granted planning permission provided that:...recovery of by-products and residues is maximised and energy recovery is maximised (utilising both heat and power)*” (page 83-84).

### **RBG – Core Strategy**

3.4.20 RBG adopted its Core Strategy with Detailed Policies in July 2014. The main policy within RBG’s Core Strategy that relates to the provision of CHP is Policy E1 – Carbon Emissions. Policy E1 is a mitigation policy which seeks to reduce carbon emissions from new development through the adoption of the Mayor’s energy hierarchy. As such, a priority of RBG is to reduce reliance on the national grid and move towards a Borough-wide decentralised low carbon energy network such as combined (cooling) heat and power. The Proposed Development strongly supports Policy E1 and the transition towards reducing reliance on the national grid by providing sustainable energy sources and decentralised energy systems, with the potential of delivering a DH scheme to developments in RBG, such as Thamesmead.

### **RBG Adopted Infrastructure Delivery Plan**

3.4.21 RBG adopted the Infrastructure Delivery Plan (21014) to support the policies outlined in the Core Strategy and identifies future infrastructure and service needs for the Borough over the next 15 years. The Plan notes that a key means of delivering efficient energy services to the Borough is through the local generation of heat and power, through community heating, combined heat and power systems or combined cooling, heat and power systems, and the establishment of a heat and power network.

## **3.5 Summary**

3.5.1 This section summarises the national, regional and local planning policy and guidance relevant to the Proposed Development in relation to the provision of CHP.

3.5.2 As outlined above, the Secretary of State is required to determine an application in accordance with any relevant NPSs and for the Proposed Development these are; NPS EN-1 and NPS EN-3 and NPS EN-5. Fundamentally, the Proposed Development meets the policy objectives of the NPSs; to deliver new energy capacity, of a renewable/low carbon supply; and to do whilst delivering the waste hierarchy.

3.5.3 At a regional level, the adopted and Draft London Plan(s) both contain a number of policies relating to the sustainable use of energy and the provision of CHP. The main policies which specifically refer to the provision of CHP include; Policy 5.6 in the adopted London Plan and draft Policy S13 in the Draft London Plan.

In summary, the Proposed Development responds directly to the identified challenges in both London Plans, provides a local source of renewable/low carbon energy recovered from London's residual waste and provides a means to reduce carbon dioxide emissions.

- 3.5.4 The local policy and guidance which relates to energy and the provision of CHP in relation to the REP DCO includes policies set by LBB, DBC and KCC. This report also considers policies set by RBG as some of the heat export opportunities discussed in this report are from proposed sites in the RBG jurisdiction. The local planning policies identify a need for climate change initiatives including the provision of decentralised energy sources. These needs will be met by the Proposed Development.
- 3.5.5 The requirements for the provision of information in the above policies are addressed in the following sections of this report.

## 4 Legislative Requirements

### 4.1 CHP-Ready Guidance

4.1.1 In February 2013, the EA produced a guidance note titled 'CHP Ready Guidance for Combustion and Energy from Waste Power Plants'<sup>2</sup>. This guidance applies to the following facilities, which will be regulated under the Environmental Permitting (England and Wales) Regulations 2016:

- new combustion power plants (referred to as power plants) with a gross rated thermal input of 50 MW or more; and
- new energy from waste (EfW) plants with a throughput of more than 3 tonnes per hour of non-hazardous waste or 10 tonnes per day of hazardous waste.

4.1.2 The ERF at REP will be regulated as a waste incineration facility with a throughput of more than 3 tonnes per hour, so the above guidance applies.

4.1.3 The EA requires developers to demonstrate BAT for a number of criteria, including energy efficiency. One of the principal ways of improving energy efficiency is through the use of CHP, for which three BAT tests exist. The first involves considering and identifying opportunities for the immediate use of heat off-site. Where this is not technically or economically possible, the second test involves ensuring that the plant is built to be CHP Ready. The third test involves carrying out periodic reviews to determine whether the situation has changed and if there are opportunities for heat use off site.

### 4.2 Energy Efficiency Directive

4.2.1 From 21<sup>st</sup> March 2015, operators of certain types of combustion installations are required to carry out a CBA of opportunities for CHP when applying for an Environmental Permit (EP). This is a requirement under Article 14 of the Energy Efficiency Directive and applies to a number of combustion installation types. As new electricity generation installation with a total aggregated net thermal input of more than 20 MWt, REP will be classified as an installation type 14.5(a).

4.2.2 In April 2015, the EA issued draft guidance on completing the CBA, entitled 'Draft guidance on completing cost-benefit assessments for installations under Article 14 of the Energy Efficiency Directive'<sup>3</sup>. The following methodology describes the process that must be followed for type 14.5(a) and 14.5(b) installations. The CBA is presented in Section 7.

---

<sup>2</sup> CHP Ready Guidance for Combustion and Energy from Waste Power Plants v1.0, February 2013

<sup>3</sup> Draft guidance on completing cost-benefit assessments for installations under Article 14 of the Energy Efficiency Directive, V9.0 April 2015

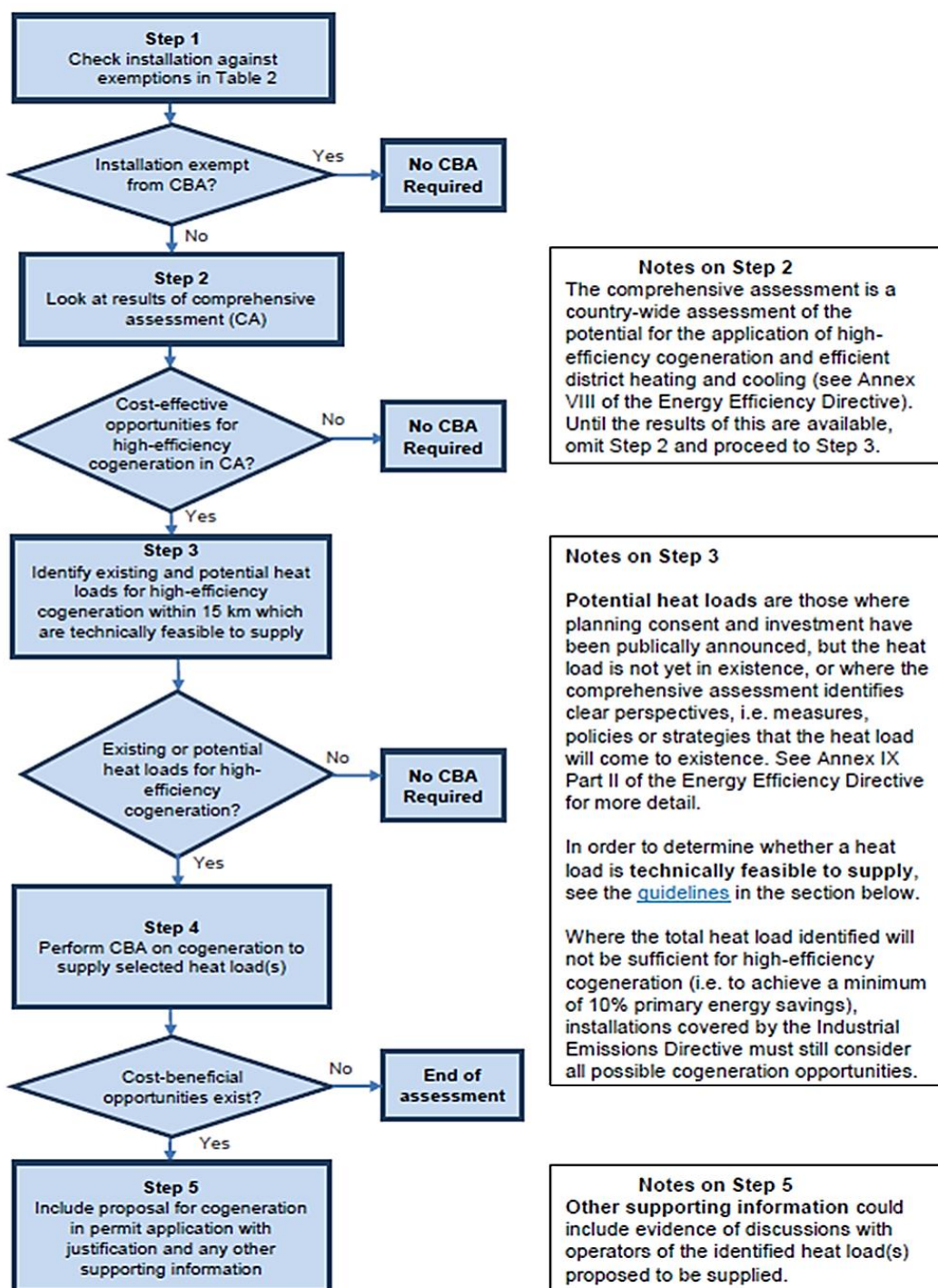

Figure 1 – CBA methodology for type 14.5(a) and 14.5(b) installations

### 4.3 Carbon Intensity Floor

4.3.1 Energy strategy proposals should aim to reduce carbon dioxide emissions through the use of zero or low-emission decentralised energy where feasible, prioritising connection to DH and cooling networks and utilising local secondary heat sources. Specifically, Policy 5.17 ‘Waste capacity’ of the London Plan stipulates that technologies generating energy from London’s non-recyclable



waste must achieve a minimum greenhouse gas performance level, known as the Carbon Intensity Floor (CIF). The CIF is set at 400 grams of carbon dioxide equivalent generated per kilowatt hour (kWh) of electricity generated. There is some degree of ambiguity within the policy wording since energy outputs including electricity, heat and biogas are accounted for within CIF modelling. Therefore, for the purposes of this assessment, the carbon emissions from REP have been considered in relation to the mass of carbon dioxide equivalent generated per kWh of energy generated, to account for export of heat and the upgrade of biogas to a transport fuel (within the Anaerobic Digestion process).

- 4.3.2 Proposal 7.3.2.b of the London Environment Strategy<sup>4</sup> aligns with the London Plan and requires that “*Waste authorities must demonstrate how solutions generating energy from waste (EFW) meet the carbon intensity floor (CIF), or put in place demonstrable steps to meet it in the short-term.*”
- 4.3.3 Meeting the CIF target effectively rules out the use of traditional mass burn incineration techniques generating electricity only and supports the take up of highly efficient technologies generating both heat and power.
- 4.3.4 The Applicant has assessed the carbon impact of the proposed waste management solution in accordance with GLA approved methodology, using the Mayor of London’s greenhouse gas (GHG) calculator model for municipal waste (version 2.1). The following input assumptions have been applied within the calculator model:
- i. Assessment year set to 2024, to align with scheduled operational start date;
  - ii. Quantity of residual waste arising set to 655,000 tonnes per annum, to align with the nominal design throughput of the REP ERF. Residual waste compositional data set as default (England), and is reproduced in Appendix A ;
  - iii. Quantity of organic waste arising set to 29,000 tonnes per annum, to align with the nominal design throughput of the Anaerobic Digestion facility. Organic compositional data has been assumed to be sourced from 33.3% food and 66.6% green waste, in accordance with LBB’s organic waste mix;
  - iv. Transport scope excluded on the basis that transport impacts are not a mandatory requirement for assessment of carbon emissions for CIF compliance purposes;
  - v. Residual waste set to arise from ‘other’, to align with CRE’s waste management strategy for supplying waste from riparian transfer loading stations;
  - vi. Residual waste destination set to energy recovery via incineration in CHP mode (in line with the proposed design); and

---

<sup>4</sup> London Environment Strategy, Greater London Authority, May 2018

- vii. Organic waste destination set to Anaerobic Digestion processing (dry, plug flow type) with biogas upgrade to transport fuel (in line with the proposed design).
- 4.3.5 Following a consultation meeting held with the GLA on 11<sup>th</sup> September 2018, the GLA advised that the waste Gross Calorific Value (GCV) should be used as a basis for the efficiency calculations in the CIF assessment. The Applicant is, however, aware of at least two projects (Edmonton EcoPark (North London) and Beddington (South London) ERF) for which a Net Calorific Value (NCV) basis was used for their respective CIF assessments. This approach was verified by the GLA’s environmental advisory consultant and accepted by the GLA. We have therefore presented both sets of figures within the model results in Table 1.
- 4.3.6 The results of the assessment indicate that the waste management technologies within REP will achieve a carbon intensity of 336 g and 283 g of carbon dioxide equivalent generated per kWh of energy generated, on a GCV and NCV basis respectively. The conclusions for the assessment have been extracted from the calculator model and are presented in Table 1. The results demonstrate that the design of the REP will comply with the requirements of the CIF.
- 4.3.7 Increasing the modelled arisings of residual waste and organics to 805,920 and 40,000 tonnes per annum respectively (to align with the likely upper end of throughput at the REP ERF and Anaerobic Digestion facility assessed for EIA purposes), would improve the carbon intensity output to 335 g and 282 g of carbon dioxide equivalent generated per kWh of energy generated, on a GCV and NCV basis respectively.

Load case	Carbon Intensity Floor (gCO <sub>2</sub> e/kWh)	
	GCV basis	NCV basis
No heat export	466	393
3 MW heat export to Anaerobic Digestion facility	451	380
30 MW heat export (to district heating)	344	290
33 MW heat export (to district heating and Anaerobic Digestion facility)	336	283

Table 1 – GHG calculator model results

## 5 Technology Description

### 5.1 Site Selection

- 5.1.1 The REP site comprises approximately 7 hectares of land located approximately at National Grid Reference (NGR) TQ 49467 80680, accessed off Norman Road, Belvedere, London DA17 6JY in the LBB, immediately to the west of the existing RRRF. An illustrative site layout is provided in Appendix B
- 5.1.2 The REP site is predominantly used by the Applicant as an ancillary area for the existing RRRF located at the same address as outlined above. The REP site includes the existing jetty in the River Thames which is currently used for delivery of waste and despatch of by-products at the existing RRRF. The jetty will be used for the same purpose for the operation of REP and there is capacity to accommodate the additional throughputs.

### 5.2 Proposed Development

- 5.2.1 REP would comprise an integrated range of technologies including: waste energy recovery, anaerobic digestion, solar panels and battery storage. Of principal importance to any potential DH network is the ERF, since this element is capable of generating thermal energy.
- 5.2.2 Subject to the selected end use of biogas (generated as part of the Anaerobic Digestion process discussed in this section), biogas would either be upgraded to compressed natural gas (CNG) for use as a vehicle fuel or combusted on site in CHP engine(s) to recover renewable energy. In the latter case, up to 1 MW of electricity and up to 1 MW of heat would be available to contribute to the energy outputs of REP. The proposed Anaerobic Digestion facility, however, may also consume heat in order to sustain the thermophilic chemical process, and could therefore potentially form part of the overall heat demand.
- 5.2.3 The other elements of REP, while fundamental to the integrated waste management and renewable energy generation solution, are not capable of exporting heat to consumers and are therefore not considered further in this report.
- 5.2.4 It is anticipated that construction of REP would commence in 2021, with an anticipated operational start date during 2024.
- 5.2.5 A technical description of the proposed REP ERF and heat supply system is provided in the following sections.

### 5.3 The Energy Recovery Facility

- 5.3.1 The REP ERF will have a design throughput of nominally 655,000 tonnes (with the likely upper end of throughput being 805,920 tonnes for EIA purposes) of C&I or MSW per annum, with an assumed NCV of 9 MJ/kg, through two

combustion lines. Annual operational availability is expected at 8,000 hours. The process is illustrated in the following schematic.

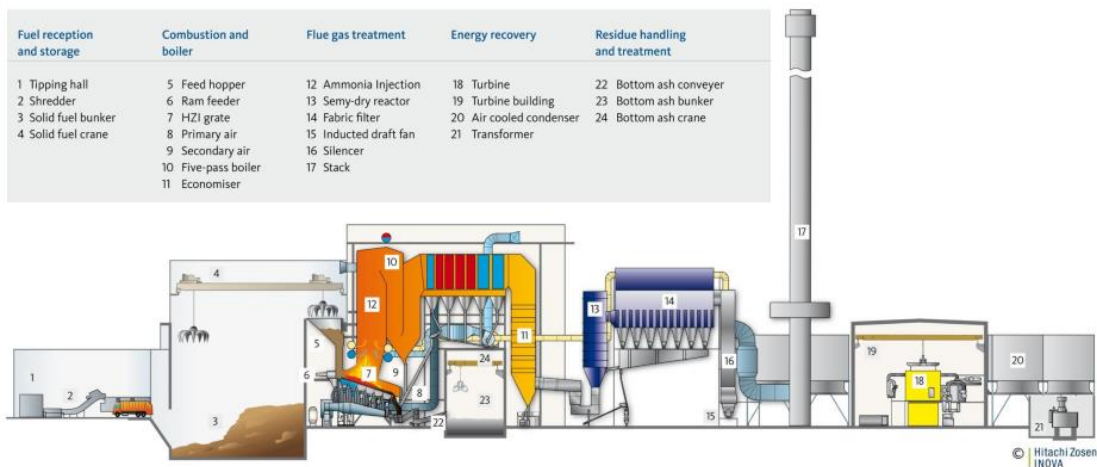

Figure 2 – REP Energy Recovery Facility schematic

5.3.2 The REP ERF will have two waste incineration lines, waste reception, waste storage, water, fuel gas and air supply systems, boilers, steam-turbine-generator, facilities for the treatment of exhaust gases, on-site facilities for treatment and storage of residues and waste water, flues, stack, systems for controlling incineration operations, recording and monitoring conditions.

5.3.3 Residual waste will be combusted on a moving grate to ensure continuous mixing of the fuel and hence promote good combustion. The heat released by the combustion of the fuel is recovered in a water tube boiler, which is integral to the furnace and will produce (in combination with superheaters) high pressure superheated steam. The steam from the boiler will feed a steam-turbine generator used to generate electricity. Exhaust steam will be cooled using an air-cooled condenser.

5.3.4 Subject to detailed design, a dedicated heat supply system, nominally 3 MWt, may be provided to support the integrated thermophilic Anaerobic Digestion process. Subject to technical and economic feasibility, a heat supply system would be included to export up to 30 MWt of heat to offsite consumers, as discussed in the following section.

## 5.4 Heat Supply System

5.4.1 Heat is typically supplied from the energy recovery process in the form of steam or hot water, depending on the grade of heat required by the end consumer(s). The most commonly considered options for recovering heat in ERFs are discussed below.

### Heat recovery from the air-cooled condenser

- 5.4.2 Wet steam emerges from the steam turbine typically at around 40°C. This energy can be recovered in the form of low grade hot water from the condenser depending on the type of cooling implemented.
- 5.4.3 An air-cooled condenser will be installed at the REP ERF. Steam is condensed in a large air-cooled system which rejects the heat in the steam into the air flow, which is rejected to atmosphere. An air-cooled condenser generates a similar temperature condensate to mechanical draught or hybrid cooling towers. However, cooling this condensate further by extracting heat for use in a heat network requires additional steam to be extracted from the turbine to heat the feedwater prior to being returned to the boiler. The additional steam extraction reduces the power generation from the plant.

### Heat extraction from the steam-turbine

- 5.4.4 Steam extracted from the steam-turbine can be used to generate hot water for a DH network, which typically operate with a flow temperature of 90 to 120°C and return water temperature of 50 to 80°C. Steam is preferably extracted from the turbine at low pressure to maximise the power generated from the steam. Extraction steam is passed through condensing heat exchanger(s), with condensate recovered back into the feedwater system. Hot water is pumped to heat consumers for consumption before being returned to the primary heat exchangers where it is reheated.
- 5.4.5 This source of heat offers the most flexible design for a heat network. However, the size of the heat load needs to be clearly defined to allow the steam bleeds and associated pipework to be adequately sized. Increasing the capacity of the bleeds once the turbine has been installed can be difficult.

### Heat recovery from the flue gas

- 5.4.6 The temperature of flue gas exiting the flue gas treatment plant is typically around 140°C and contains water in vapour form. This can be cooled further using a flue gas condenser to recover the latent heat from the moisture. This heat can be used to produce hot water for DH in the range 90 to 120°C. This method of heat recovery does not significantly impact the power generation from the plant.
- 5.4.7 Condensing the flue gas can be achieved in a wet scrubber. However, the scrubber temperature is typically no more than 80°C, which restricts the hot water temperature available for the consumer. Additionally, condensing water vapour from the flue gas reduces the flue gas volume and hence increases the concentration of non-condensable pollutants within it. The lower volume of cooler gas containing higher concentrations of some pollutants would likely require a different stack height to effect adequate dispersion. The additional cooling of the flue gas also results in the frequent production of a visible plume from the chimney and, although this is only water vapour, it can be

misinterpreted as pollution. The water condensed from the flue gas needs to be treated and then discharged under a controlled consent.

5.4.8 For the REP ERF, steam extraction from the steam-turbine is likely to offer the most favourable solution for the following reasons:

- i. Extraction of steam from the steam-turbine offers the most flexibility for varying heat quality and capacity to supply variable demands or new future demands, which is particularly relevant for facilities intended to supply DH networks with a mix of consumers;
- ii. The heat requirements of the identified consumers (as described in Section 6) are suited to the temperatures attainable from the turbine with minimal power loss due to exporting energy to the heat circuit;
- iii. The use of a flue gas condenser would generate a visible plume which would be present for significant periods of the year. This is not desirable as it would significantly add to the visual impact of the ERF; and
- iv. This approach aligns with the design of the adjacent RRRF (discussed in Section 6.8), while incorporating technological advancements made available since the facility commenced commercial operations in 2011.

## 6 Heat Demand Investigation

- 6.1.1 A review of the potential heat demand within a 10 km radius of the REP site has been undertaken to assess potential known or consented future developments that may require heat and to identify any existing major heat consumers. This enabled the initial design of proposed heat network options to be developed. Potential heat consumers have been identified using a review of publicly available datasets on fuel use in the region, heat mapping tools and visual inspection of satellite imagery, as discussed in the following sections.
- 6.1.2 The viability of connecting potential identified heat users to a DH network has been considered on the basis of maximising carbon savings and delivering the highest Primary Energy Savings (PES), while minimising heat losses through pipe route optimisation. Larger heat consumers and those closer to the REP site have been prioritised ahead of other consumers on the basis they are more likely to yield an economically viable solution.

### 6.2 Anaerobic Digestion Facility

- 6.2.1 REP will include an Anaerobic Digestion facility, sized to process up to 40,000 tonnes of food and green waste per annum. The Anaerobic Digestion facility will utilise a thermophilic chemical reaction to breakdown the feedstock into biogas, which will be either (subject to detailed design) upgraded for use as CNG vehicle fuel or combusted within CHP engine(s) to generate renewable electricity and heat. In order to sustain this process, the Anaerobic Digestion facility will require a source of heat. Subject to detailed design, this could be supplied as nominally 3 MWt of low pressure steam (extracted from the turbine via the low pressure header) to supply up to 12 dryer units. This arrangement is shown in the indicative heat and mass balance provided in Appendix C .
- 6.2.2 The Anaerobic Digestion facility forms part of the integrated REP solution and therefore potentially presents a secure, although relatively modest, heat demand. Heat demand is anticipated to vary based on the quantity and composition of treated waste, which are dependent on the season. Since waste specification and variability is unknown at this stage, we have assumed that steam consumption will remain constant at the rate guaranteed by the technology provider.

Estimated heat demand (MWh/annum)	Estimated average heat demand (MWt)	Estimated peak heat demand (MWt)
24,000	3.0	3.0

Table 2 – Anaerobic Digestion facility heat demand

- 6.2.3 In the outline design case, heat would be supplied to the Anaerobic Digestion facility in the form of steam (rather than hot water), and would therefore not be supplied through the DH network supply system. Provisions for heat export to the Anaerobic Digestion facility would comprise dedicated steam supply and

condensate return pipework. The export of heat to the Anaerobic Digestion facility would represent an eligible heat use and has therefore been included in the energy efficiency measures presented in 10.6.

### 6.3 Wider Heat Export Opportunities

#### The National Comprehensive Assessment

6.3.1 'National Comprehensive Assessment of the Potential for Combined Heat and Power and DH and Cooling in the UK'<sup>5</sup>, dated 16<sup>th</sup> December 2015, was published by Ricardo AEA Ltd on behalf of the Department of Energy and Climate Change (DECC). The report was produced to fulfil the requirement (under Directive 2012/27/EU on energy efficiency) on all EU Member States to undertake a National Comprehensive Assessment (NCA) to establish the technical and socially cost-effective potential for high-efficiency cogeneration. The report also sets out information pertaining to heat policy development in the UK.

6.3.2 Section 3 of the report presents the results of the NCA. REP is located 2.3 km to the north of Belvedere in the London Borough of Bexley, which falls within the London region of the assessment. Aggregated 2012 heat consumption and equivalent figures projected to 2025, split by sector, are presented in the following table.

Sector	2012 consumption (TWh/annum)	2025 consumption (TWh/annum)
Industry (including agriculture)	2	2
Commercial services	3	2
Public sector	3	2
Residential	34	30
<b>Total</b>	<b>42</b>	<b>37</b>
We assume that the apparent discrepancy in the figures is due to rounding errors. We do not have access to the underlying data to verify this.		

Table 3 – Heat consumption in London

6.3.3 Evidently there is a downward trend in heating consumption anticipated in subsequent years. The energy projections take account of climate change policies where funding has been agreed and where decisions on policy design

---

<sup>5</sup> National Comprehensive Assessment of the Potential for Combined Heat and Power and DH and Cooling in the UK, Ricardo AEA, December 2015



are sufficiently advanced to allow robust estimates of policy impacts to be made, including measures such as building regulations.

6.3.4 Similarly, current and projected space cooling consumption data is reported as follows. Given the paucity of publicly available data on energy consumption for cooling, these figures are estimates based on consumption indicators, building types and floor areas; consequently, they should be considered as indicative.

Sector	2012 consumption (TWh/annum)	2025 consumption (TWh/annum)
Industry (including agriculture)	3	3
Commercial services	13	11
Public sector	1	1
<b>Total</b>	<b>18</b>	<b>15</b>

We assume that the apparent discrepancy in the figures is due to rounding errors. We do not have access to the underlying data to verify this.

Table 4 – Cooling consumption in London

6.3.5 Due to the low resolution of the data, the results of the NCA can be considered as an overview only. Heat demand from the residential sector is above the national average, while demand from industrial consumers is lower than average. A high cooling demand from the commercial services sector is also apparent. A conventional DH network serving a number of low grade heat consumers would therefore likely be a favourable solution in the area under consideration.

6.3.6 Higher resolution heat demand data is ascertained from heat mapping, as explained in the following sections.

### National Heat Mapping

6.3.7 Potential heat loads have been identified using a review of publicly available datasets on the Department for Business, Energy and Industrial Strategy (BEIS) (formerly the Department of Energy and Climate Change) National Heat Map<sup>6</sup>. This allows the heat demand in the area local to REP to be determined. The tool geographically represents the heat demand across various sectors within England and helps to identify locations where implementation of heat networks is likely to be most economic.

6.3.8 Table 5 shows the heat demand, in MWh per year, for all sectors and building types within 10 km of REP. This is represented as coloured contour areas in

---

<sup>6</sup> <http://nationalheatmap.cse.org.uk/>

Figure 3, with each colour band representing a range of heat demand density values.

Sector	Heat demand (MWh/annum)	Heat demand (%)	Number of addresses
Commercial offices	120,420	1.5%	4,714
Education	203,744	2.5%	637
Government buildings	107,238	1.3%	196
Health	73,880	0.9%	1,108
Hotels	145,770	1.8%	1,282
Industrial	538,389	6.5%	817
Mining	991	0.0%	3
Other	38,525	0.5%	430
Postal	8,661	0.1%	340
Recreational	98,642	1.2%	1,285
Residential	5,829,745	70.2%	507,786
Retail	469,550	5.7%	13,145
Science	66	0.0%	3
Transport	663,975	8.0%	2,988
<b>Total</b>	<b>8,299,596</b>	<b>100.0%</b>	<b>534,734</b>

Table 5 – Heat demand within 10 km search radius

6.3.9 With the exception of public buildings, the heat map is produced entirely without access to the meter readings or energy bills of individual premises. Therefore, the results should be taken as an estimate only.

6.3.10 The area surrounding REP comprises heat demand predominantly from the residential, transport, industrial and retail sectors. This differs from the typical distribution observed throughout the UK as a result of the high proportion of industrial estates, distribution centres and warehousing facilities located in close proximity to the REP site.

6.3.11 In most cases, existing domestic buildings are unsuitable for inclusion in a DH network as a result of the prohibitive costs of replacing existing heating infrastructure and connecting multiple smaller heat consumers to a network. However, new housing developments can represent a viable option and are discussed further in Section 6.4.

Riverside Energy Park  
 Riverside Energy Park CHP Study

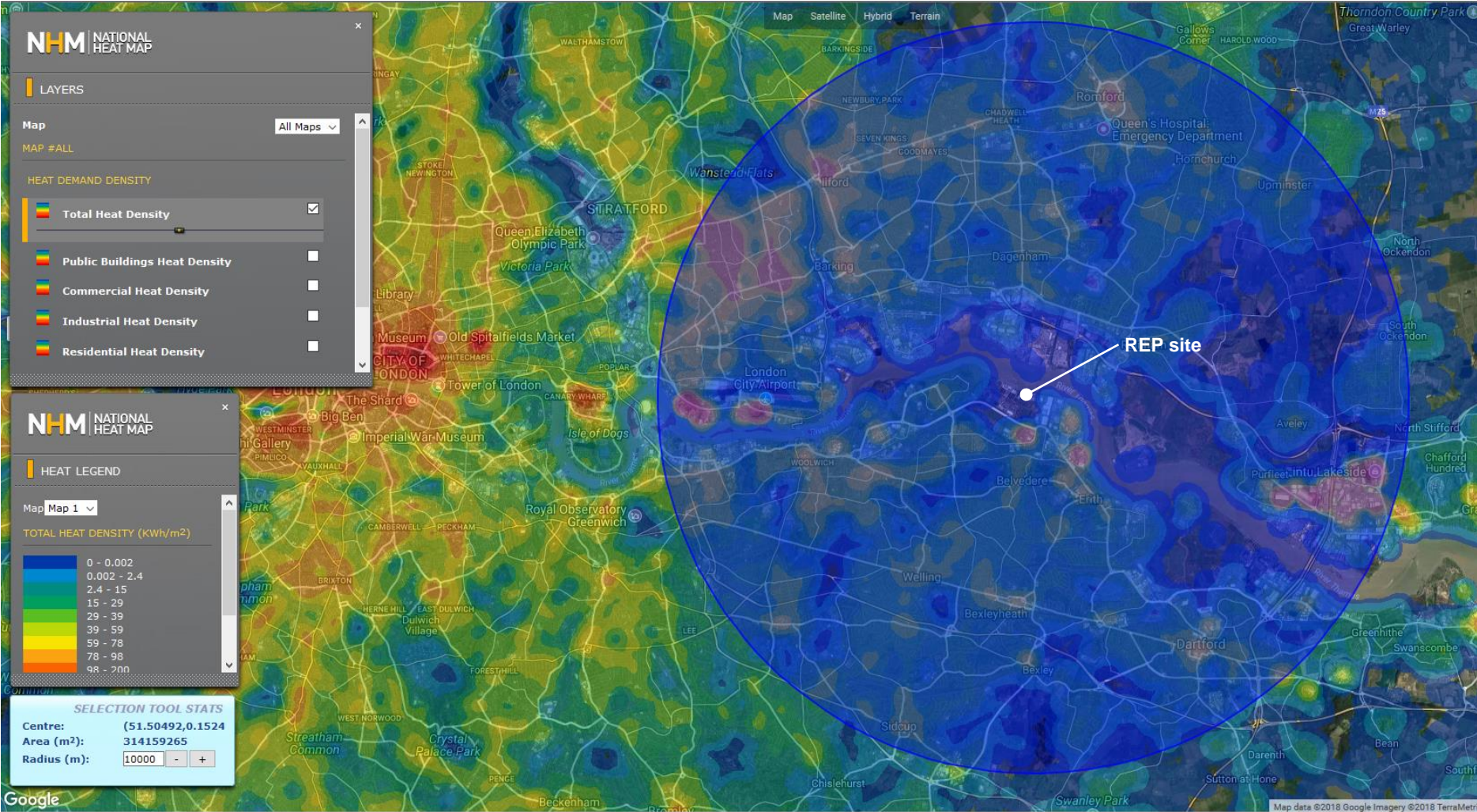

Figure 3 – Local heat demand density, all sectors, National Heat Map

## London Heat Map

6.3.12 The London Heat Map<sup>7</sup> has been developed by the GLA to assist authorities and developers in identifying opportunities for decentralised energy projects in London. The map was created to drive the delivery of the Mayor's overarching energy policies.

6.3.13 The map indicates that there are no existing DH networks in the LBB but decentralised energy potential in the locality of REP is reported as high. Potential heat consumers superimposed with areas of decentralised energy potential are presented in Figure 4, being:

- i. Lower Belvedere, located directly to the south of the REP site, presents high potential for DH network deployment. Given the nature of heat demand in the locality (multiple smaller residential units and education facilities), connecting to heat consumers within Lower Belvedere would only be feasible in conjunction with connection to larger prospective developments in the area (as discussed in Section 6.4);
- ii. The town of Erith, located 3.1 km to the south-east of the REP site, also appears to contain a reasonable degree of heat demand, but with a much higher proportion of existing residential properties, for which connection costs are likely to be prohibitive. The North Kent railway line also presents a barrier to heat pipe routing in the area;
- iii. The town of Woolwich / West Thamesmead, located 6 km to the west of the REP site, presents high potential for DH deployment. There are a range of existing public establishments and private commercial premises, in addition to a number of proposed developments (as discussed in Section 6.4); and
- iv. Areas of DH potential in the towns of Welling and Bexleyheath, located 5.7 km and 5.9 km respectively to the south of the REP site, are unlikely to offer realistic connection prospects. Anchor loads within the areas are limited and therefore unlikely to offset connection costs, and any pipeline would have to negotiate both the North Kent and Bexleyheath railway lines.

---

<sup>7</sup> <https://www.london.gov.uk/what-we-do/environment/energy/london-heat-map/view-london-heat-map>

# Riverside Energy Park Riverside Energy Park CHP Study

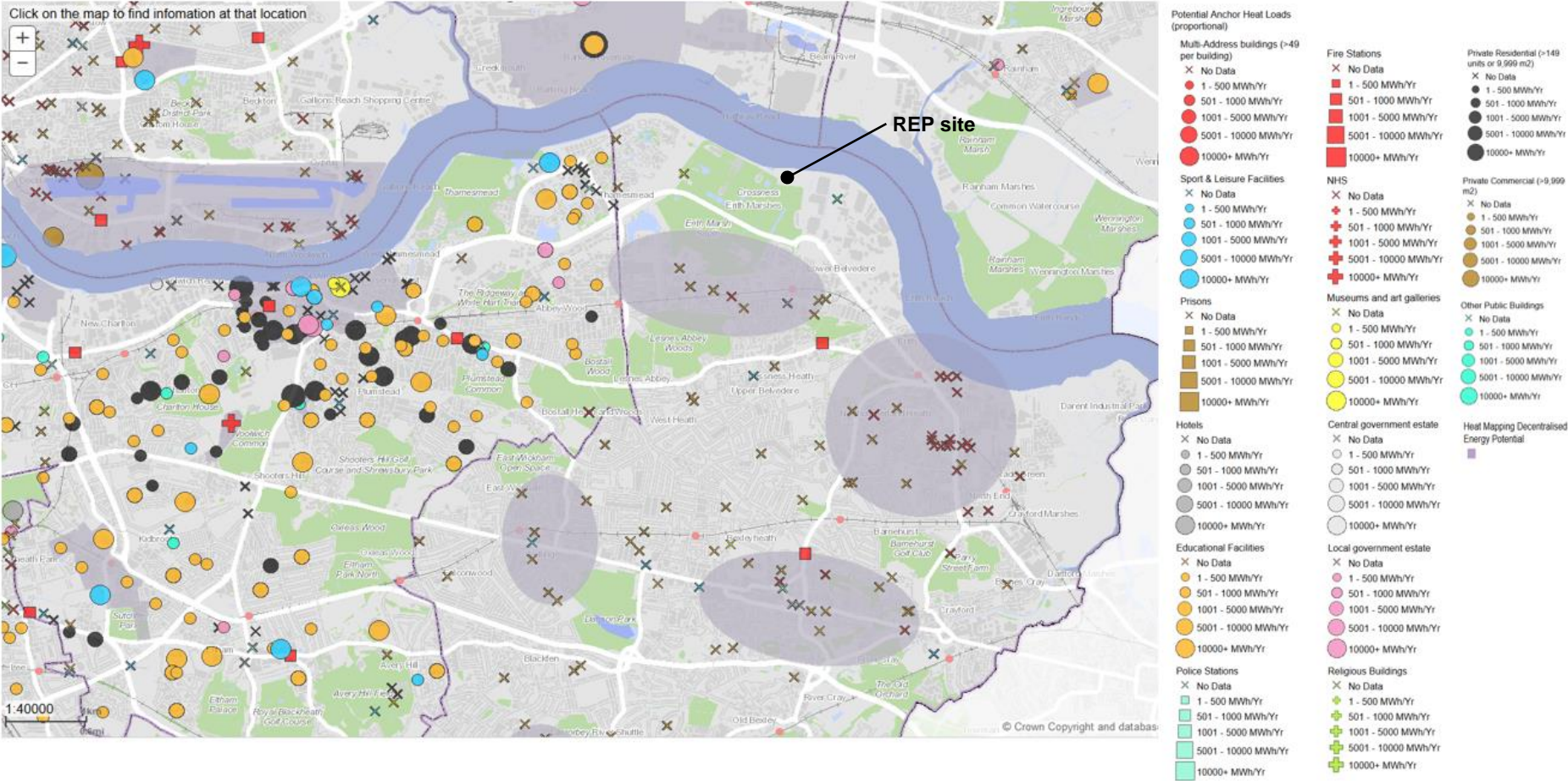

Figure 4 – Decentralised energy potential, London Heat Map

## Large Heat Consumers

6.3.14 Four large heat consumers (point heat demands greater than 5 MWt) were identified within 10 km of REP using the BEIS UK CHP Development Map<sup>8</sup> tool.

Site	Heat demand (MWh/annum)	Distance from REP	Postcode
London City Airport	145,161	7.2 km west	E16 2PX
Unknown operator	124,648	2.5 km north	RM9 6SA
Archer Daniels Midland	213,204	1.8 km south east	DA8 1DL
Unilever Foods	65,155	8.1 km south east	RM19 1SD

Table 6 – Large heat consumers

6.3.15 Of the identified large heat consumers, only Archer Daniels Midland, a rapeseed oil refinery, is located on the south bank of the River Thames. The heat demand requirements of this industrial facility are likely to exceed the grade of heat available from the REP ERF. Given the industrial nature of the site, it is likely that high grade heat (steam) may be required and the practicality of collecting and returning condensate is unknown. These considerations are likely to worsen the technical and economic feasibility of a connection. Additionally, the business owner would need to be willing to contribute to the cost of upgrading existing heating systems to accept heat from a network, and to accept the resulting operational interruptions, which may present major barriers.

6.3.16 The remaining large heat loads have been discounted on the basis of connection feasibility. Based on our engineering assessment, connecting to sites to the north of the River Thames would not be feasible. The grade of heat required for the remaining large heat loads, and whether the REP ERF could meet this requirement, is unknown. Development types (where known) include existing heat supply infrastructure on site, which would further reduce connection prospects. Additionally, without additional anchor loads nearby, connection costs to the heat loads in remote locations are likely to be prohibitive.

---

<sup>8</sup> <http://chptools.decc.gov.uk/developmentmap/>

# Riverside Energy Park Riverside Energy Park CHP Study

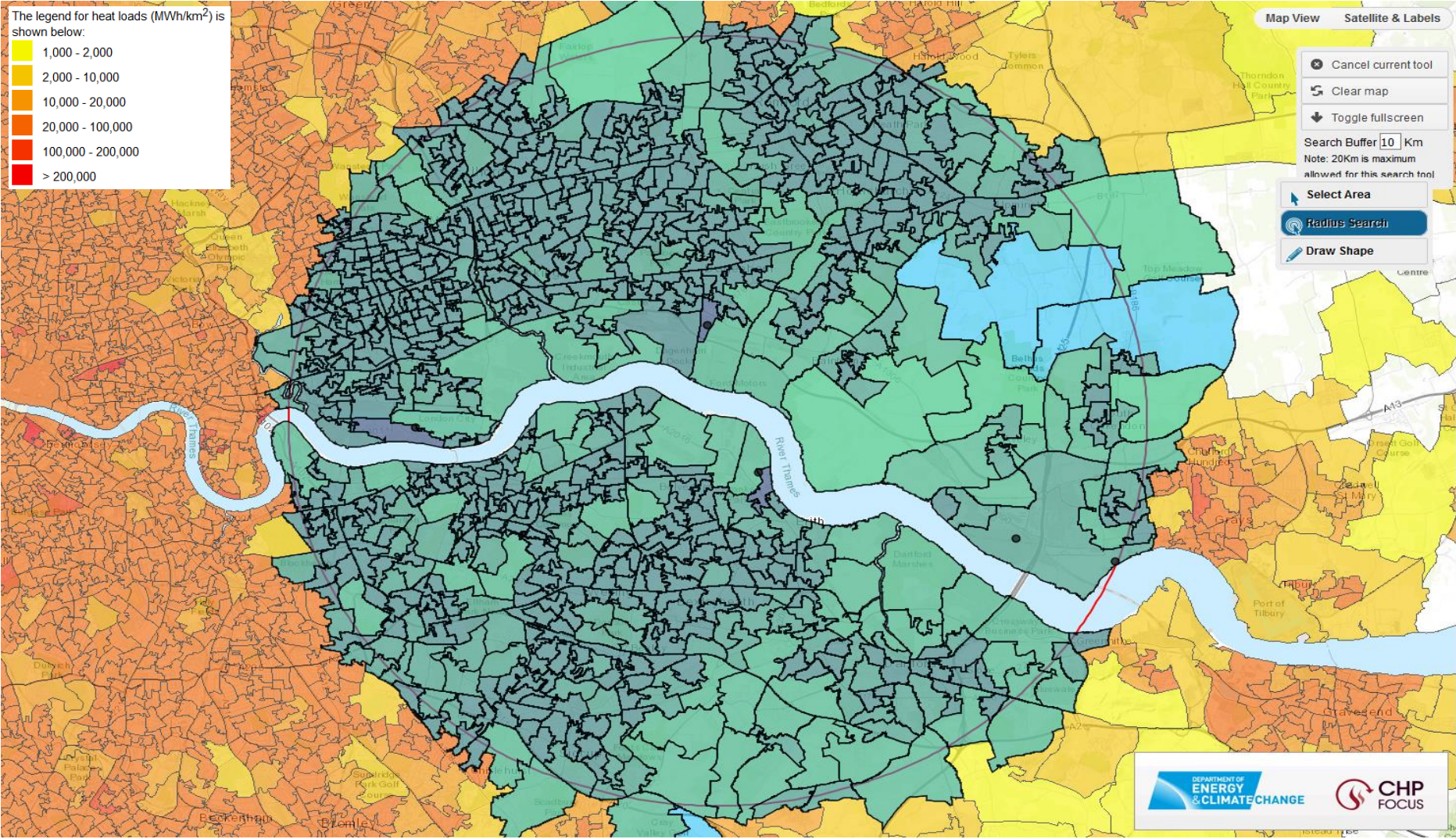

Figure 5 – Large heat consumers, UK CHP Development Map



## Visual Inspection

- 6.3.17 Broad assumptions were made regarding the estimated heat demand from existing potential heat consumers. Heat demands have been calculated based on benchmark figures from the Chartered Institution of Building Services Engineers (CIBSE) Guide F (Energy Efficiency in Buildings)<sup>9</sup>. This document provides good practice benchmark figures based on energy performance of existing buildings. In the CIBSE Guide, loads are expressed in terms of kWh per square metre of floor space per year of fossil fuel use (natural gas is typically assumed). Based on estimates of floor areas and an assessment of the development type, it is possible to estimate annual energy usage. Converting natural gas use to actual heat loads (which can be provided by a hot water distribution system) requires an assumption of gas-fired boiler efficiency; an efficiency of 85% is assumed, based on industry norms.
- 6.3.18 A list of potential heat consumers identified within 10 km of REP, applying engineering judgement to screen out unfavourable routes, is provided in Appendix D . A corresponding map is provided in Appendix E .

## 6.4 Prospective Developments

- 6.4.1 Engagement with potential developers is a key aspect of delivering a DH scheme. The Applicant is an active member of the District Heat Network Working Group and has engaged in discussions with the London Borough of Bexley, Royal Borough of Greenwich, GLA, and Peabody Estates, a London based housing developer, regarding heat export opportunities to proposed developments in Thamesmead.
- 6.4.2 Up to 20,000 dwellings and commercial properties are proposed as part of a Thamesmead regeneration programme, although the development proposals are at various stages within the planning process and may therefore be subject to change. Publicly available information has been used to inform heat demand projections, which are listed in Table 7. Locations of the proposed developments are provided in Appendix E .

---

<sup>9</sup> CIBSE Guide F: Energy Efficiency in Buildings

Riverside Energy Park  
Riverside Energy Park CHP Study

Scheme	Development proposals	Estimated heat demand (MWh/annum)		Estimated average heat demand (MW)		Estimated peak heat demand (MW)	
		Residential	Commercial	Residential	Commercial	Residential	Commercial
Thamesmead Waterfront	Masterplan has been developed outlining the potential to deliver up to 11,500 homes and 94,000m2 of commercial floorspace. Scheduled completion date mid 2020s.	79,181	5,194	9.09	0.60	30.86	1.70
Land at Binsey Walk	To provide up to 329 residential units and 1,050m2 of commercial floorspace. Scheduled completion date 2024.	3,780	178	0.43	0.02	1.47	0.06
Southmere Village	525 homes, public lakeside square, library, cafes, convenience store and community facilities. Scheduled completion date 2024.	1,647	521	0.19	0.06	0.64	0.17
Land at Coraline Walk	To provide up to 549 residential units and 3,225m2 of commercial floorspace. Scheduled completion date 2024.	3,780	178	0.43	0.02	1.47	0.06
Land at Sedgemere Road	To provide up to 219 residential units and 3,225m2 of commercial floorspace. Scheduled completion date 2024.	1,508	178	0.17	0.02	0.59	0.06
The Reach	A mix of 1,2 & 3 bedroom homes and 66 commercial units. Under construction - scheduled completion date 2019.	339	219	0.04	0.03	0.13	0.07
West Thamesmead Gateway	1,300 residential units and 5,763m2 of commercial floorspace. Scheduled completion date mid 2020s.	7,522	318	0.86	0.04	2.93	0.10
<b>Total</b>		<b>97,758</b>	<b>6,787</b>	<b>11.22</b>	<b>0.78</b>	<b>38.10</b>	<b>2.22</b>

Table 7 – Proposed developments as part of Thamesmead regeneration

- 6.4.3 Community heating in the UK has been difficult to implement historically due to the existence of an extensive natural gas network and a regulated energy supply market which allows customers the freedom to change suppliers to obtain preferential commercial terms. The high cost of infrastructure is also a barrier to community heating, with a notable lack of domestic pipe suppliers. Developers of private residential properties are reluctant to utilise community heating as it often increases development costs.
- 6.4.4 Community heating can be successful in circumstances where:
- i. new-build housing developments are aligned with low carbon heat sources in terms of timing and proximity;
  - ii. developments offer heat demand density, for example apartment blocks;
  - iii. there is a high level of Local Authority / housing association properties; and
  - iv. additional (non-residential) consumers are also connected to the network to improve network diversity and offset seasonality issues.
- 6.4.5 These preferential circumstances exist in the case of REP.
- 6.4.6 With the exception of The Reach scheme, which is currently under construction, construction programmes align with development timeframes for REP, which is anticipated to commence operations in 2024. Since retrofitting a network connection to The Reach scheme, which represents a relatively small demand, is unlikely to offer an economically viable case, the scheme has not been included within the proposed DH network solution.

## 6.5 Heat Consumer Screening

- 6.5.1 The design of any heat network is the critical component in defining the technical and financial viability of a DH scheme. This section seeks to review the various potential network options and heat supply considerations that feed into the financial modelling based on the estimated heat demands and physical constraints.
- 6.5.2 Physical constraints imposed by local infrastructure and topology have a significant impact on which consumers can viably be connected. Both river and rail crossings exist in the area surrounding REP and present obstructions to connect some consumers. Engineering a bridge crossing will likely require detailed structural assessments and the consent of the bridge owner. Trenching in road crossings will require traffic management and permission from the highway authority. Taking these factors into account, we have identified two potential DH network options, which are distinguished primarily on the basis of heat consumer location and whether the developments are existing or proposed.
- 6.5.3 **Option 1** – Connect prospective new housing and commercial developments to the west of the REP site. Timing of network installation will be crucial to avoid

retrofitting of heating systems and associated high costs. Collaboration from the developer and local planning authorities will be required to drive forward non conventional heating systems. Connecting to new developments exclusively will have the benefit of reducing system operating temperatures, which will increase the amount of heat that can be exported and reduce heat losses. Additional environmental benefits could be attained through integration with other low carbon heat sources.

- 6.5.4 **Option 2** – Connect businesses located to the south and east of the REP site. These areas have a high heat demand density with a number of high heat demand premises. However, the heat demand requirements of individual businesses, and whether the REP ERF could supply the heat grade required, is unknown. Additionally, business owners would need to be willing to contribute to the cost of upgrading existing heating systems to accept heat from a network, and to accept the resulting operational interruptions, which may present major barriers.
- 6.5.5 For the reasons explained above, Option 1 is the preferred solution and has been taken forwards for consideration. An economic assessment of the preferred DH network solution is presented in Section 7.
- 6.5.6 The Applicant is committed to maximising the benefits associated with developing the REP ERF as CHP. Should heat export to consumers identified within option 1 not materialise, the Applicant intends to engage with businesses identified within this study and captured under option 2, to assess technical and economic feasibility of connection.

## 6.6 Heat Network Profile

- 6.6.1 Generic heat demand profiles were developed to model the seasonal and diurnal variation in heat demand for each of the individual heat consumers identified, by integrating the estimated annual heat demands (in MWh). This allowed the annual average and peak heat demands (in MWt) to be calculated. A combined heat demand profile for the proposed heat network was then derived from the sum of the individual heat load profiles of the selected consumers.
- 6.6.2 The heat network profile for the proposed heat network, shown in Figure 6, includes heat demand from the proposed residential and commercial developments in Thamesmead (with the exception of The Reach). The heat network profile illustrates the variation in heat demand during a typical day in different seasons, accounting for network heat losses and demand diversity.

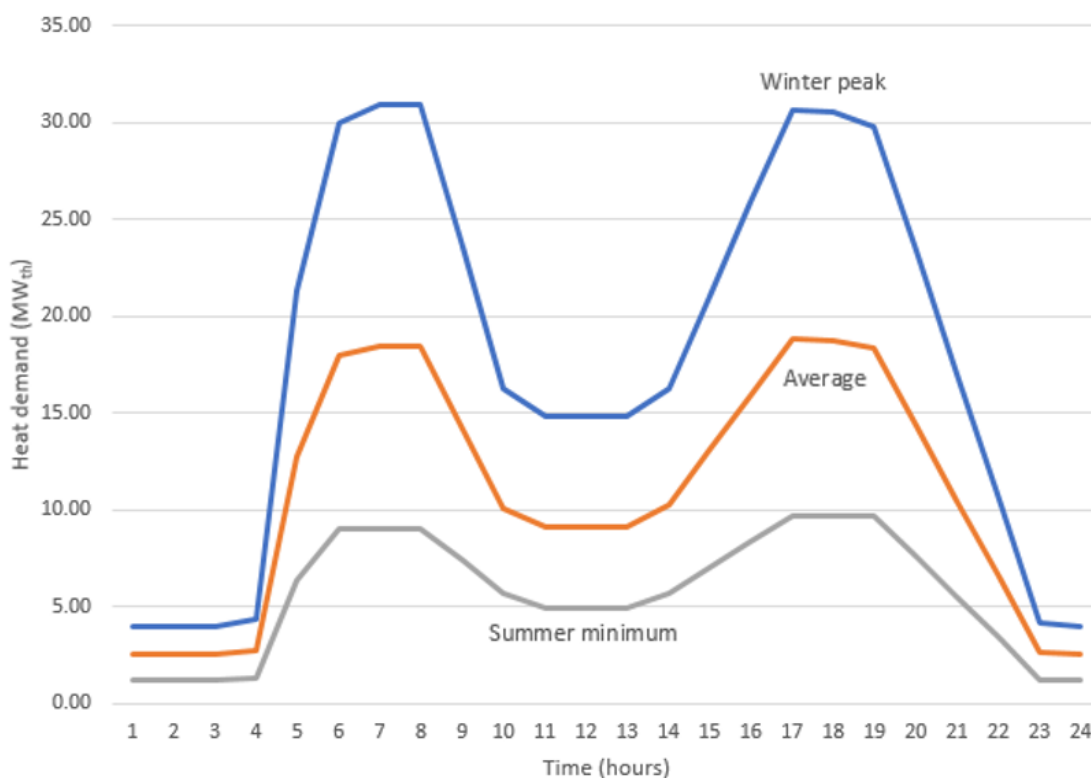

Figure 6 – Projected heat network profile showing daily and seasonal variation

Consumers connected	Estimated heat demand (MWh/annum)	Estimated average heat demand (MW)	Estimated peak heat demand (MW)
1, 2, 3, 4, 5, and 7 (see map in Appendix E )	114,385	10.89	30.89

Table 8 – Preferred DH network parameters

6.6.3 Based on the generic heat network profile developed, the preferred DH network offers a heat demand which aligns with the capacity and grade of heat available from the REP ERF. We note however that additional public establishments and private commercial premises exist in the town of Woolwich / West Thamesmead, which is located along the proposed DH pipeline corridor. Subject to the level of uptake achieved on deployment of a DH network and final pipe routing, owners of these existing developments will be approached to determine appetite for and feasibility of connection. For the purposes of this report, given the scale of heat demand offered by prospective developments, existing developments have not been explored further at this stage.

## Heat Load Duration Curve

- 6.6.4 The heat load duration curve presented in Figure 7 displays the instantaneous heat demand for the proposed heat network, arranged in order of decreasing magnitude, across the year.
- 6.6.5 Since detailed heat demand data is not available at this stage, we have developed the heat load duration curve based on instantaneous heat demand at each hour of the day for each month, producing a total of 288 data points (24 hours/day x 12 months/year).

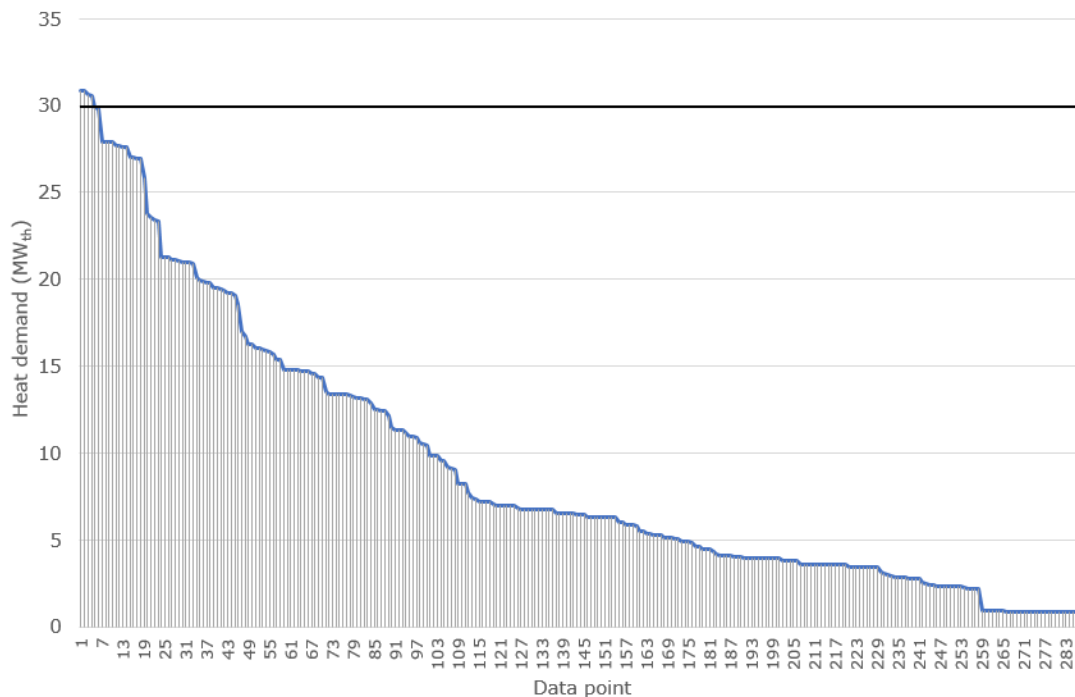

Figure 7 – Heat load duration curve

- 6.6.6 The estimated peak demand of the proposed DH heat network is 30.9 MW<sub>t</sub>, but the REP ERF will be designed with a heat export capacity of up to 30.0 MW<sub>t</sub>. Therefore, the peak heat load could not be met by the REP ERF independently. We estimate that the heat demand would exceed the maximum heat export capacity for less than 2% of the year, so the shortfall is marginal. A back-up system would still be required during periods of plant downtime (as described in Section 6.8).
- 6.6.7 Projected peak loads are likely to exceed the maximum heat export capacity so peak lopping plant or accumulators (thermal stores) may be required. Heat accumulators can be used to manage peak heat demand to avoid the use of fossil fuelled peak lopping boilers, by storing excess heat generated during off-peak periods for supply at times of peak heat demand (reducing the total installed capacity of plant required). This decouples heat production from heat demand, improving the operational flexibility of a CHP plant. Heat accumulators

are typically large water tanks; as heat is absorbed the temperature rises and as heat is extracted the temperature decreases.

## Demand Diversity

6.6.8 Significant daily and seasonal variation in heat demand is typical for heat networks serving residential and commercial consumers, which form the basis of the proposed DH network. Increasing the number and type of consumers connected to a DH network diversifies heat demand and helps to reduce the impact of the peak demand of any individual consumer, since it is less likely that peak demands will coincide. In calculating the diversified heat demand, we have assumed a diversity factor of 0.7, in accordance with CIBSE AM12<sup>10</sup>, which is considered best industry practice for mixed use networks.

## 6.7 Heat Network Design

6.7.1 Heat distribution between REP and offsite heat consumers would use buried pipework. Pre-insulated steel pipes are used to supply pressurised hot water to the customer, and to return cooler water. Where pipes are small, two pipes may be integrated within a single insulated sleeve. For larger heat demands, large bore pipes are installed as a single insulated run. Pipe technology is well proven and can provide a heat distribution system with a 30 year plus design life. Additional pipe work can be added retrospectively, and it is reasonably straightforward to add branches to serve new developments.

6.7.2 Modern heat-insulated piping technology enables hot water to be transferred large distances without significant losses. Where the topography creates challenges, heat exchangers and additional pumping systems can be installed to create pressure breaks, enabling the network to be extended.

6.7.3 Heat delivery arriving at a consumer's premises usually terminates using a secondary heat exchanger. The heat exchanger is typically arranged to supply heat to a tertiary heating circuit upstream of any boiler plant. The water in the tertiary circuit is boosted to the temperature required to satisfy the heating needs of the building.

6.7.4 Water is pumped continuously around the system. Pumps are operated with 100% standby capacity to maintain heat in the event of a pump fault. Pumps are likely to utilise variable speed drives to minimise energy usage.

6.7.5 The following design criteria relate to a typical hot water network utilising conventional heat extraction (as detailed in Section 5.4) and have been used to size the heat transmission pipe diameters. Flow and return temperatures have been selected to align with operating temperatures for newer heating systems, with a view to reducing network heat losses.

---

<sup>10</sup> CIBSE AM12 Combined Heat and Power for Buildings, 2013

Parameter	Value
Water supply temperature to consumer	90°C
Water return temperature from consumer	60°C
Distance between flow and return pipes	150mm
Soil temperature	10°C
Depth of soil covering (minimum)	600mm

Table 9 – District heating network typical design criteria

6.7.6 Using the above design criteria and taking into account the estimated heat demand for the preferred network, the primary hot water transmission pipe size has been calculated as DN400. This is an indicative figure and will be subject to heat demand verification and subsequent network design.

## 6.8 Back-up Heat Source

6.8.1 The REP ERF will be designed to achieve an availability of over 90% (i.e. at least c. 8,000 operational hours per year). During periods of routine maintenance or unplanned outages the plant will not be operating, however the heat consumers will still require heat. There is therefore a need, somewhere within the heat distribution system, to provide a back-up source of heat to meet the needs of the heat consumers. It is anticipated that the back-up boilers will be in operation for c. 760 hours per year.

6.8.2 The standby plant will likely comprise oil or gas-fired hot water heaters (boilers) with a separate dedicated stack. Back-up boilers are typically designed to ensure that the peak heat export capacity can be met but also provide sufficient turndown to supply smaller summer loads with reasonable efficiency. An indicative arrangement would be the installation of one 15 MWt unit, one 10 MWt unit and one 6 MWt unit. The location of the back-up boilers would be decided after the grant of DCO but would be located within the parameters of Work Number 3, as shown on the Works Plans (**Document Reference 2.2**), but it would be preferential to locate the boilers in close proximity to the heat consumers to minimise heat losses when running on fossil fuel.

6.8.3 Subject to detailed heat demand modelling, once heat consumers are known with more certainty, opportunities for installing thermal stores will be considered to lessen reliance on the back-up plant by storing excess heat generated during off peak periods for use during times of peak heat demand.

6.8.4 The cost of installing and operating back-up plant has been included in the economic assessment (see Section 7).



## 6.9 Additional Heat Sources

- 6.9.1 To maximise the benefits associated with developing a heat network, a review of heat sources in the area surrounding REP has been undertaken. Additional heat sources could be used to increase the capacity of the heat network and the associated benefits.
- 6.9.2 According to the National Heat Map, there are six point heat sources within 10 km of REP.
- i. Barking Reach, a 1,000 MWe combined cycle gas turbine (CCGT) power station, located approximately 1.8 km to the north of REP, was decommissioned in 2014;
  - ii. Littlebrook D, a 1,475 MWe oil-fired power station, located approximately 7.6 km to the south-east of REP, but was decommissioned in 2015;
  - iii. A 19.5 MWe CHP installation is located approximately 7.4 km to the west of REP at the Thames Refinery;
  - iv. A 3.8 MWe CHP installation is located approximately 2.6 km to the north east of REP at Maple Lodge Sewage Treatment Works;
  - v. A 10.0 MWe CHP installation is located approximately 7.1 km to the south east of REP at Arjo Wiggins Ltd; and
  - vi. A 3.5 MWe CHP installation is located approximately 7 km to the south east of REP at Longreach Sewage Treatment Works.
- 6.9.3 Given the stated electrical capacities, the quantity of surplus heat (if any) available from these CHP installations is likely to be too small to make any connection viable. Additionally, the location of operational heat supply assets does not align with areas of high DH network potential, as identified in preceding sections of this study. On this basis, inclusion of additional heat sources captured on the National Heat Map are not considered feasible.
- 6.9.4 The Applicant operates the RRRF, a three-stream ERF with a maximum consented waste throughput of 785,000 tonnes per annum of MSW, including a proportion of waste from C&I sources. The RRRF is capable of generating up to 72 MWe through a conventional combustion process. The RRRF is located on land directly to the east of the REP site off Norman Road, Belvedere. The RRRF has been operated successfully since Take-Over was achieved in October 2011 and presents a robust back-up heat source, with availability and thermal export capacity broadly equivalent to that of the proposed REP ERF.
- 6.9.5 Consent for the RRRF was secured on the basis that the facility was developed as fully condensing (i.e. designed to export electricity only) but included a condition to facilitate heat supply to future DH networks. Condition 30 of the planning permission requires that *“A facility shall be provided and maintained within the development to enable steam passouts and/or hot water pass-outs*

*and reserve space for the provision of water pressurisation, heating and pumping systems for off-site users of process or space heating". This condition was complied with as follows.*

- 6.9.6 The steam turbine has three extraction bleeds which are utilised for process heating to maximise efficiency of the thermal cycle. Low pressure steam at approximately 4 bar(a) is supplied from a 'sliding-bleed' arrangement, comprising two bleeds connected to a common header. At high inlet steam flows to the turbine, the lower pressure bleed supplies steam to the low pressure header; at reduced inlet steam flows, the lower pressure bleed is closed, and steam is supplied from the higher pressure bleed.
- 6.9.7 When the turbine is operating at low load or is out of operation, no steam is available for feeding consumers from the low pressure steam header. In this case, steam is administered directly to the header from the high pressure live steam supply via a pressure reducing valve.
- 6.9.8 In June 2015, the Applicant installed isolation valves on the low pressure steam header to facilitate steam extraction for potential future heat export, although the remaining heat export infrastructure including the DH pipelines, are yet to be installed. The RRRF is able to supply up to 30 MWt of heat to a DH network in the future, subject to commercial viability. Identification of additional heat demand (beyond that of the preferred DH network identified in this study) would likely be required to yield a feasible economic case.

## **6.10 Indicative Pipe Route**

- 6.10.1 An indicative layout of the preferred DN network is provided in Appendix F . The routing is indicative; a detailed engineering assessment would be required to determine the optimum route, which is not appropriate for this initial study.
- 6.10.2 The predominant engineering issue associated with the supply of heat by hot water relates to the installation of the heat supply pipeline. The pipe line required to supply hot water is likely to be a pair of large diameter pipes which must be installed in a trench. Determining a feasible route for such a pipeline is complex as outlined below.
- 6.10.3 Existing buried services may obstruct the most direct route to end consumers. Infrastructure crossings may be required and the supply and return pipelines would need to be routed along public highways. These issues have a direct bearing on the cost and installation time.
- 6.10.4 To install heat supply infrastructure, such as pre-insulated DH pipes, in the public highway, the installer would need to comply with the requirements of the New Roads and Street Works Act 1991 (NRSWA). This lays out the legal obligations that apply to both statutory and non-statutory undertakers wishing to install apparatus in the public highway. Failure to comply can lead to fines and/or an order to remove the apparatus.

6.10.5 The provisions of the NRSWA do not apply to works carried out in private land, which would include the REP site where consent to install DH pipes and CHP infrastructure is being secured within this DCO application. Outside of the REP site, DH pipes would be brought forward by the associated heat load developer or relevant local authority.

## 7 Economic Assessment

### 7.1 Fiscal Support

7.1.1 The following fiscal incentives are available to energy generation projects, and a number of these could support the delivery of REP.

#### Capacity Market for electricity supplied by the plant

7.1.2 Under the Capacity Market, subsidies are paid to generators to ensure long term energy security for the UK. The Capacity Market does not prioritise low-carbon energy or specific technologies. Capacity Agreements are awarded in a competitive auction and new plants (such as REP) are eligible for contracts lasting up to 15 years. The Applicant intends to secure a Capacity Agreement for the electricity supplied by REP.

#### Renewable Heat Incentive (RHI)

7.1.3 The RHI was created by the Government to promote the deployment of heat generated from renewable sources. To be eligible, the plant in question must not receive any other support or subsidy from public funds. Since the Applicant will receive support under the Capacity Market, it will not be eligible for the RHI. In addition, no funding announcements have been published for the RHI post March 2021.

#### Contracts for Difference (CfD)

7.1.4 CfD has replaced the Renewables Obligation (RO) as the mechanism by which the Government supports low carbon power generation. CfD de-risks investing in low carbon generation projects by guaranteeing a fixed price (the Strike Price) for electricity over a 15 year period. In the second CfD round (executed on 11<sup>th</sup> September 2017) no funding was allocated for conventional ERF, with or without CHP, so this mechanism will likely not be a source of financial support for REP.

#### Heat Network Investment Project (HNIP) funding

7.1.5 The HNIP aims to deliver carbon savings and create a self-sustaining heat network market through the provision of subsidies for DH projects. £320 million has been made available (through grants and loans) to fund the HNIP over the next five years. Following a pilot scheme, which ran from October 2016 to March 2017, first applications for the main HNIP funding scheme are expected in Q3 2018. BEIS has confirmed that funding will be available for both public and private sector applicants, and that there will be no constraints on scheme size.

7.1.6 Grant funding, to assist local authorities in heat network project development, is also available through the Heat Networks Delivery Unit (HNDU). The LBB has secured funding to undertake a detailed feasibility assessment and heat pipe route options appraisal in mid to late 2018. The Applicant intends to engage

with LBB's project team to support development of the proposed DH network through to implementation.

## 7.2 Technical Feasibility

7.2.1 Step 3 of the CBA methodology requires identification of existing and proposed heat loads which are technically feasible to supply, as carried out in Section 6 of this study. The draft Article 14 guidance states that the following factors should be accounted for when determining the technical feasibility of a scheme, pertaining to a type 14.5(a) installation.

### i. The compatibility of the heat source(s) and load(s) in terms of temperature and load profiles

The preferred DH network solution is intended to supply heat, in the form of hot water, to new-build residential and commercial developments in Thamesmead. On this basis, it will be possible to reduce system operating temperatures and heat losses in line with best industry practice.

Development proposals indicate that a DH supply temperature of circa 90°C will be sufficient to meet the requirements of the anticipated end users. The indicative heat and mass balance (provided in Appendix C ) demonstrates that the REP ERF would be designed to supply hot water at up to 100°C, and as such the heat source and loads are considered compatible.

Heat export will be facilitated through steam extraction from the turbine, prioritised as follows to maximise energy efficiency.

- a. When the REP ERF is operating at full load, steam will be supplied through a low pressure bleed at 0.7 bar(a), corresponding to 30 MWt export.
- b. In low load operation or when network demand exceeds capacity available through the low pressure bleed, steam will be supplied through a low pressure steam header, supplied via a turbine bleed at 4.1 bar(a), corresponding to 30 MWt export.

Connecting to new developments exclusively will have the benefit of reducing system operating temperatures, which will increase the amount of heat that can be exported and reduce heat losses. Additional environmental benefits could be attained through integration with other low carbon heat sources.

As we have undertaken our analysis using generic consumer heat profiles, consumer requirements (in terms of hot water temperature and load profiles) will need to be verified prior to the implementation of a heat network.

### ii. Whether thermal stores or other techniques can be used to match heat source(s) and load(s) which will otherwise have incompatible load profiles

A thermal store or back-up boilers (as detailed in Sections 6.6 and 6.7 respectively) will likely be included in the DH network to ensure continuity of supply. The thermal store will take precedence over any peak lopping plant to ensure that low carbon energy provision is prioritised. The specific arrangement will be selected when there is more certainty over heat loads.

### **iii. Whether there is enough demand for heat to allow high-efficiency cogeneration**

‘High-efficiency cogeneration’ is cogeneration which achieves at least 10% savings in primary energy usage compared to the separate generation of heat and power. Primary Energy Saving (PES) are calculated in the following section.

## **7.3 Primary Energy Savings (PES)**

7.3.1 In order to be considered high-efficiency cogeneration, the scheme must achieve at least 10% savings in primary energy usage compared to the separate generation of heat and power. PES have been calculated in accordance with Directive 2012/27/EU Annex II part (b), using the following assumptions.

- i. Annual nominal throughput of 655,000 tonnes per annum based on a NCV of 9 MJ/kg;
- ii. Gross electrical output for the ERF (fully condensing mode) of c. 70 MWe;
- iii. Parasitic load of 6.1 MWe (i.e. electricity consumed within the REP site);
- iv. Z ratio (ratio of reduction in power export for a given increase in heat export) of 8, based on EPC contractor proposal; and
- v. Efficiency reference values for the separate production of heat and electricity have been taken as 80% and 25% respectively as defined in Annexes 1 and 2 of Commission Delegated Regulation (EU) 2015/2402<sup>11</sup>.

7.3.2 When operating in fully condensing mode (i.e. without heat export) the REP ERF would achieve PES of 27.0%, which is in excess of the technical feasibility threshold defined in the draft Article 14 guidance. The inclusion of heat export at 13.9 MWt, as anticipated for the proposed heat network (including both DH network and Anaerobic Digestion facility consumers), increases PES to 30.0%. On this basis, the REP ERF would qualify as a high efficiency cogeneration operation when operating in CHP mode and a CBA is therefore required.

## **7.4 Cost-benefit Assessment**

7.4.1 Under Article 14 of the Energy Efficiency Directive (EED), operators of certain types of combustion installations are required to carry out a CBA of opportunities for CHP when applying for an EP. We have followed the EA’s

---

<sup>11</sup> <http://eur-lex.europa.eu/legal-content/EN/TXT/PDF/?uri=CELEX:32015R2402&from=EN>

methodology, as outlined in the draft Article 14 guidance, in order to appraise the economic feasibility of implementing the proposed heat network.

7.4.2 The CBA uses an Excel template, 'Environment Agency Article 14 CBA Template.xlsx' provided by the EA, with inputs updated to correspond with the specifics of this CHP Study. The CBA model takes into account:

- i. revenue streams (heat sales and fiscal benefits);
- ii. expenditure streams (construction and operational, including back up plant); and
- iii. lost electricity sales revenue, over the lifetime of the scheme.

7.4.3 Model inputs and key outputs are provided in Appendix G . The following assumptions have been made.

- i. The scheme will commence operation in 2024 to align with projected build out programmes for REP and the prospective Thamesmead developments;
- ii. The heat export infrastructure is estimated to have a capital cost of approximately £14.4 million, split over a two-year construction programme;
- iii. A back-up boiler will be provided to cover periods of unavailability, at a cost of approximately £3.1 million;
- iv. Operational costs have been estimated based on similar sized projects;
- v. Triad payments at the commencement of operations will be £3/kW following Ofgem's recent announcement<sup>12</sup> to reduce triad payments to embedded generators. Due to their marginal value, other embedded benefits have not been accounted for;
- vi. Heat sales revenue will be £12/MWh, index linked for inflation;
- vii. Electricity sales revenue will be £60/MWh, index linked for inflation;
- viii. The Capacity Market will form the principal fiscal benefit for REP. National Grid would apply a de-rated capacity margin to REP's electrical connection capacity as part of the standard pre qualification process to account for the expected reliability of the facility. If the facility were to apply as CHP technology, the de-rating factor would likely be 90% based on the values published by National Grid for previous auction years; and
- ix. A clearing price of £17.08/kW/year has been calculated based on the average clearing price achieved in the past four relevant T-4 Capacity Market auctions. This revenue estimate assumes the plant meets the requirements for payment under the Capacity Market Rules. This estimate

---

<sup>12</sup> <https://www.ofgem.gov.uk/publications-and-updates/ofgem-proposes-lower-payments-embedded-generators-reduce-costs-consumers>

does not account for any potential financial penalties which may be incurred, or any over delivery payments achieved, in each delivery year.

- 7.4.4 The results of the CBA indicate that the nominal project internal rate of return and the net present value (before financing and tax) over 32 years are negative. Since RHI funding cannot be claimed in conjunction with other forms of state aid, the Applicant will not receive any long-term financial support for the exported heat. As a result, the returns based on heat sales revenue alone are unattractive. We therefore consider that the proposed heat network does not yield an economically viable scheme in its current configuration.
- 7.4.5 The Applicant is committed to exploring project delivery models and financial mechanisms to realise a scheme.
- 7.4.6 It may be possible to secure funding under the HNIP (as discussed in Section 7.1) to improve the economic case through provision of capital funding. Additionally, the Applicant is exploring delivery models with key network stakeholders to identify viable scenarios. The economic feasibility of the scheme should be reassessed in the future when there is more certainty over heat loads and in light of any developments to the subsidy landscape.
- 7.4.7 The draft Development Consent Order submitted with the application (**Document Reference 3.1**) incorporates a requirement in Schedule 2 that requires the Applicant to monitor and review the potential for CHP and to report the findings to LBB.



## 8 Energy Efficiency Measures

### 8.1 Heat and Power Export

8.1.1 The Z ratio, which is the ratio of reduction in power export for a given increase in heat export, can be used to calculate the effect of variations in heat export on the electrical output of the facility. When operating in CHP mode, a Z ratio of 8 is proposed, via steam extraction from low pressure turbine bleeds. This extraction pressure is considered sufficient to meet the requirements of the consumers that comprise the proposed DH network. Modelling of heat and power export has been undertaken across a range of load cases and the results are presented in Table 10.

Load case	Heat export (MWt)	Net power export (MWe)	Z ratio
No heat export	0.0	63.9	N/A
Proposed network heat load <sup>1</sup>	13.9	62.1	8.0
Maximum heat export capacity <sup>1</sup>	33.0	60.0	8.0

<sup>1</sup>Including heat supplied to both the Anaerobic Digestion process and the DH network.

Table 10 – Heat and power export

### 8.2 CHPQA Quality Index

8.2.1 The Combined Heat and Power Quality Assurance programme (CHPQA) is an energy efficiency best practice programme initiative by the UK Government. CHPQA aims to monitor, assess and improve the quality of CHP in the UK. In order to prove that a plant is a 'Good Quality' CHP plant, as required under the CHP-Ready Guidance, a QI of at least 100 must be achieved. The QI for CHP schemes is a function of their heat efficiency and power efficiency according to the following formula.

$$QI = X\eta_{power} + Y\eta_{heat}$$

where:  $\eta_{power}$  = power efficiency; and

$\eta_{heat}$  = heat efficiency.

8.2.2 The power efficiency within the formula is calculated using the gross electrical output, and is based on the gross calorific value of the input fuel. The heat efficiency is also based on the gross calorific value of the input fuel. The

coefficients X and Y are defined by CHPQA based on the total gross electrical capacity of the scheme and the fuel/technology type used.

8.2.3 In October 2016, the Government released a revised Guidance Note 4410 entitled 'Use of CHPQA in respect of the Renewables Obligation and Contracts for Difference'. The document sets out revisions to the design and implementation of the CHPQA scheme, including amendments to the X and Y values used within the QI formulae. This is intended to ensure schemes which receive Government support are supplying significant quantities of heat and delivering intended energy savings. The following factors apply to the proposed REP ERF:

- X value = 350; and
- Y value = 120.

8.2.4 We have calculated the QI and efficiency values (based on a gross calorific value of 10.8 MJ/kg) in accordance with Guidance Note 44 for various load cases and the results are presented in Table 11.

Load case	Gross power efficiency (%)	Heat efficiency (%)	Overall efficiency (%)	CHPQA QI
No heat export	28.5	0.0	28.5	99.9
Proposed network heat load	28.0	5.7	33.6	104.7
Maximum heat export capacity	27.2	13.5	40.7	111.3

Table 11 – Heat and power export

8.2.5 The results indicate that the REP ERF would achieve a QI score in excess of the 'Good Quality' CHP threshold (QI of 100) for the average heat load exported to the proposed DH network. This corresponds to an average total heat demand of 13.9 MWt, comprising 3 MWt to support the thermophilic Anaerobic Digestion process and 10.9 MWt for the DH network. **The scheme therefore represents BAT for energy efficiency and environmental performance through the application of CHP, as defined by CHPQA.**

## 9 EA CHP-Ready Guidance

- 9.1.1 The EA has published detailed guidance on CHP Assessments as part of the Environmental Permitting regime.
- 9.1.2 The EA requires EP applications to demonstrate BAT for a number of criteria, including energy efficiency. One of the principal ways of improving energy efficiency is through the use of CHP. The EA therefore requires developers to satisfy three BAT tests in relation to CHP. The first involves considering and identifying opportunities for the use of heat off-site, as demonstrated in this CHP study. Where this is not technically or economically possible and there are no immediate opportunities, the second test involves ensuring that the plant is built to be CHP Ready. The third test involves carrying out periodic reviews to determine whether the situation has changed and there are opportunities for heat use offsite.
- 9.1.3 If the REP ERF design is developed on the basis of exporting heat to support the Anaerobic Digestion facility, which is considered an eligible heat use, the ERF would operate as a CHP plant from the outset, meaning a CHP-Ready assessment would not be required. However, since there is some uncertainty around exporting heat to the Anaerobic Digestion facility and since opportunities have been identified to increase the heat export capacity through implementation of a DH network, a CHP-Ready Assessment has been carried out. The assessment demonstrates that REP is designed to be ready, with minimum modification, to supply heat in the future.

### 9.2 CHP Envelope

- 9.2.1 The 'CHP envelope' as outlined under requirement 2 of the CHP-Ready Guidance, which identifies the potential operational range of a new plant where it could be technically feasible to operate electrical power generation with heat generation, is provided in Figure 8.
- 9.2.2 The points defining the CHP envelope are as follows.
- A: minimum stable load (with no heat extraction);
  - B: minimum stable load (with maximum heat extraction);
  - Line A to B: minimum electrical power output for any given heat load (corresponds to the minimum stable plant load);
  - C: 100% load (with maximum heat extraction);
  - D: 100% load (with no heat extraction);
  - Line D to C: maximum electrical power output for any given heat load (corresponds to 100% plant load);

- E: proposed operational point of the plant, based on the proposed heat network;
- Unrestricted operation: if a selected heat load is located in this region, the plant will have the ability to operate at any load between the minimum stable plant load and 100% plant load whilst maintaining the selected heat load; and
- Restricted operation: if a selected heat load is located in this region, the plant will not have the ability to operate over its full operational range without a reduction in heat load.

9.2.3 In this context, the CHP efficiency ( $\eta_{\text{CHP}}$ ) is defined as:

$$\eta_{\text{CHP}} = (\text{Net heat output} + \text{Net power output}) / (\text{Thermal input})$$

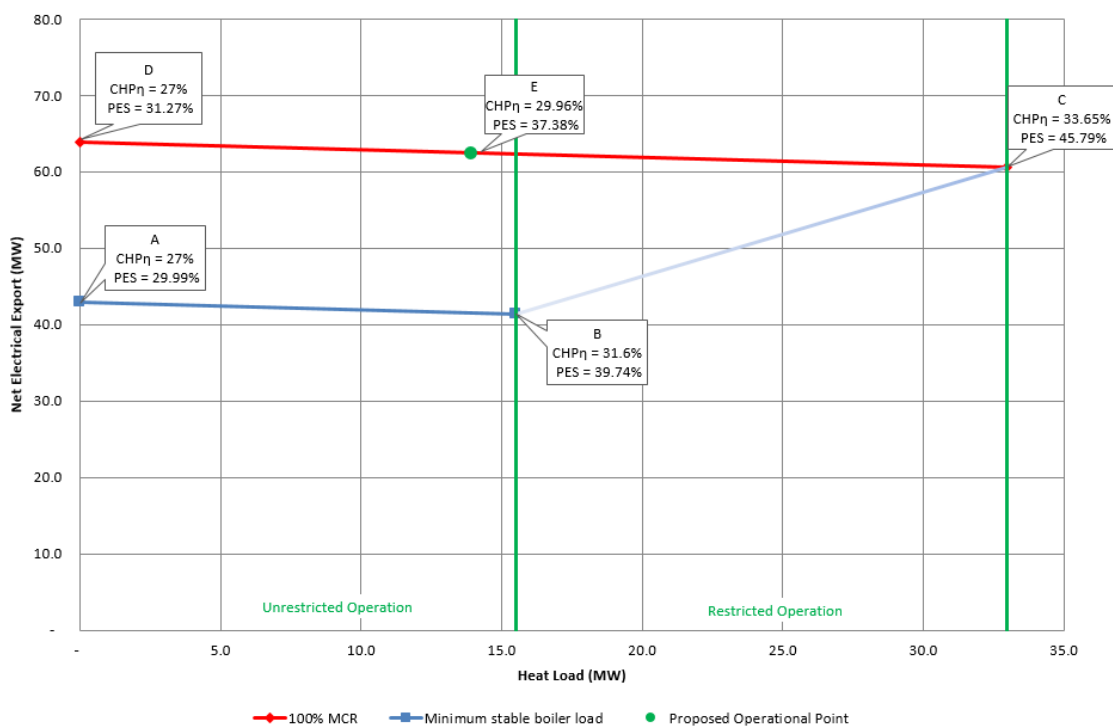

Figure 8 – Graphical representation of CHP envelope for REP network

9.2.4 The proposed operational point (point E) represents the annual average heat demand exported by the REP ERF to support the thermophilic Anaerobic Digestion process and the DH network.

### 9.3 CHP-Ready Assessment

9.3.1 A CHP-Ready Assessment form has been prepared and is provided in Appendix H .

## **9.4 CHP-Ready Provisions**

- 9.4.1 The Applicant has engaged with a preferred technology provider, Hitachi Zosen Inova AG (HZI), to progress design and provide supporting information for the DCO application and EP. HZI has undertaken outline design of the development and prepared an illustrative masterplan which includes a CHP plant room located adjacent to the turbine hall to facilitate steam and condensate interfaces. The CHP plant room would contain all of the main heat supply system equipment including heat exchangers, circulation pumps, expansion vessel, water treatment plant and associated components. The CHP plant room is sized to house equipment required to deliver the maximum heat export capacity from the REP ERF and if required, the RRRF.
- 9.4.2 The indicative heat and mass balance (provided in Appendix C ) demonstrates that the REP ERF would be designed to supply hot water at up to 100°C via suitable low pressure steam extractions from the turbine.

## 10 Conclusions

### 10.1 Policy

- 10.1.1 In accordance with section 104 of the PA 2008, the application for the DCO will be determined by the Secretary of State, in accordance with the relevant NPSs. As noted in Section 3 of this report, in the context of this scheme, the relevant NPSs are EN-1 and EN-3 and, in respect of the Electrical Connection, EN-5. These documents set out the assessment principles which should be taken into consideration for energy NSIPs. This report demonstrates clear compliance with NPSs EN-1 and EN-3 as it provides evidence that REP would be CHP Enabled from the onset and that the heat demands required and potential heat networks proposed to supply the heat are existing, under construction or proposed (specifically propose developments as part of the Thamesmead regeneration).
- 10.1.2 These NPSs are the principal policies against which the application will be determined. However, section 104 also provides that, in deciding a DCO application, the Secretary of State must have regard to any matters which the Secretary of State thinks are both important and relevant. Regional and local planning policies (including emerging policies such as the Draft London Plan) are likely to be regarded as important and relevant matters in the context of this application. The relevant regional and local planning policy and guidance, as set out in the GLA's Adopted and Draft London Plans(s), LBB's Core Strategy, DBC's Core Strategy, RBG's Core Strategy and KCC's Minerals and Waste Local Plan, support the recovery of waste and that, if feasible, facilities should accommodate the provision of CHP. The Adopted and Draft London Plan(s) and LBB's Sustainable Design and Construction SPD also require developments to examine the opportunity to extend CHP systems beyond application sites to adjacent sites and follow the hierarchy of energy systems, of which the Proposed Development accords to.
- 10.1.3 Chapter 4 of the LBB EMP identifies RRRF as the primary heat source. The Applicant has worked closely with LBB and GLA in preparing the LBB EMP to ensure that benefits of any potential CHP opportunities are maximised.
- 10.1.4 The LBB EMP identifies an opportunity for the RRRF to supply heat to the Peabody Thamesmead housing estate, Belvedere Growth Area and Yarnton Way employment land developments as part of a new district heat network. The Applicant is engaged in discussions with LBB, RBG and Peabody Estates regarding heat export opportunities.
- 10.1.5 As such, the work undertaken in this report is underpinned by and supports the requirements of the national, regional and local policy position in relation to the provision and/or opportunity for CHP. By virtue of offering a waste management solution, utilising high efficiency, technologies to generate heat, power and a transport fuel (subject to design development), REP is able to comply with the Carbon Intensity Floor (CIF) target outlined in the Adopted and Draft London Plan(s) and the London Environment Strategy.

## 10.2 Technical Solution

- 10.2.1 The Applicant has engaged with a preferred technology provider, HZI, to deliver REP comprising a waste ERF, battery storage, a roof mounted solar photovoltaic installation and an Anaerobic Digestion facility.
- 10.2.2 In fully condensing mode, the ERF would generate a significant proportion of REP's overall gross electrical output. Through co-location and potential for integration with the ERF, the opportunity also exists to have a dedicated heat supply system to support the integrated thermophilic Anaerobic Digestion process. The ERF could therefore be built as CHP from the outset, but the Applicant has also identified a wider opportunity to maximise the benefits associated with heat export by considering a DH scheme.
- 10.2.3 Subject to technical and economic feasibility, a heat supply system will be included to export up to 30 MWt of heat to offsite consumers. Design proposals indicate that the REP ERF would be capable of delivering hot water at up to 100°C via low pressure steam extraction from the steam turbine, and sufficient space has been safeguarded within the REP Site for the installation of the required infrastructure to achieve the maximum heat export capacity.
- 10.2.4 The most likely solution for implementing a DH network would be to transfer heat to a closed hot water circuit via a series of condensing heat exchangers. It is typical to supply hot water to consumers through a pre-insulated buried pipeline, before being returned to the plant for reheating. This technology is well proven and highly efficient.

## 10.3 Heat Demand Investigation

- 10.3.1 A review of the potential heat demand within a 10 km radius of REP has been undertaken in accordance with the requirements set out in Section 4 of the EA's CHP Ready Guidance. The area surrounding the REP site comprises heat demand predominantly from the residential, transport, industrial and retail sectors, primarily due to high proportion of industrial estates, distribution centres and warehousing facilities located to the south and east of the REP site.
- 10.3.2 In most cases, existing domestic buildings are unsuitable for inclusion in a DH network as a result of the prohibitive costs of replacing existing heating infrastructure and connecting multiple smaller heat consumers to a network. However, seven prospective residential and commercial developments have been identified to the west of the REP site in Thamesmead. The Applicant is engaging with the developer (Peabody) and local planning authorities regarding feasibility of connecting up to 20,000 new residential dwellings and additionally commercial premises. Connecting to new developments exclusively will have the benefit of reducing system operating temperatures, which will increase the amount of heat that can be exported and reduce heat losses.
- 10.3.3 Of the four existing large heat consumers identified (using the BEIS UK CHP Development Map) only Archer Daniels Midland, a rapeseed oil refinery, is

located on the south bank of the River Thames and could therefore present a connection prospect. This potential consumer may offer an anchor load for future connections to businesses in the locality. However, the heat demand requirements of individual businesses, and whether the REP ERF could supply the heat grade required, is unknown. Given the industrial nature of the sites, it is likely that high grade heat (steam) may be required and the practicality of collecting and returning condensate is unknown. These considerations are likely to worsen the technical and economic feasibility of a connection. Additionally, business owners would need to be willing to contribute to the cost of upgrading existing heating systems to accept heat from a network, and to accept the resulting operational interruptions, which may present major barriers.

10.3.4 Developing a DH network to initially serve new-build consumers within Thamesmead would present the most favourable configuration. Work undertaken in the LBB EMP has also identified this as a realistic and deliverable project. With the exception of one scheme which is currently under construction, the prospective developments are due to complete mid 2020s and therefore align with the construction programme for REP, which is anticipated to commence operations and reliability testing in 2024. The Applicant has worked with LBB on developing the EMP which has strong support from key stakeholders.

#### **10.4 Heat Network Profile**

10.4.1 Based on publicly available development proposals, we have estimated the heat demand of the preferred heat consumers. A heat demand profile has been developed to model the seasonal and diurnal variation of the preferred DH network option. Accounting for network heat losses and diversity, a heat demand of 114,385 MWh/annum is projected, equating to an average and peak demand of 10.9 MWt and 30.9 MWt respectively. The capacity and grade of heat available from the REP ERF aligns with the projected network heat demands. Additional capacity could potentially be added to the network by connecting existing developments in the town of Woolwich / West Thamesmead, which is located along the proposed DH pipeline corridor. Subject to the level of uptake achieved on deployment of a DH network and final pipe routing, owners of these existing developments will be approached to determine appetite for and feasibility of connection.

10.4.2 The heat demand profile indicates that base loads, including the anticipated demand from the onsite Anaerobic Digestion facility, could be met by the REP ERF independently, except for periods of downtime when a back-up system would be required. Projected peak loads are likely to exceed the maximum heat export capacity, so that peak lopping plant or accumulators (thermal stores) may be required. Incorporation of an accumulator would minimise the use of fossil fuelled peak lopping boilers, by storing excess heat generated during off-peak periods for supply at times of peak heat demand. Alternatively, the existing RRRF, which has been operated reliably by the Applicant since 2011, could be utilised to supply network peak demands or when REP is unavailable.



10.4.3 The adjacent RRRF is configured as CHP-Ready and in 2015, the Applicant implemented modifications to the low pressure steam system to facilitate steam extraction for potential future heat export. Assuming sufficient additional heat demand could be identified and connected, the RRRF could be utilised to increase the capacity of the heat network by up to 30 MWt, or to complement REP by increasing the resilience of the heat supply system.

## 10.5 Economic Assessment

10.5.1 We have assessed the costs and revenues associated with the construction and operation of the proposed DH network and have inputted these values into the CBA template provided by the EA. The CBA takes account of heat supply system capital and operating costs, heat sales revenue and lost electricity revenue as a result of diverting energy to the heat network.

10.5.2 The principal fiscal support mechanism for REP would be the Capacity Market, so the exported heat would not qualify for support under the Renewable Heat Incentive (RHI). The results of the CBA indicate that the estimated £17.6 million capital investment would not be offset by heat sales revenue alone. The nominal project internal rate of return and net present value (before financing and tax) over 32 years (comprising 2 year build and 30 year operational life) would be negative. We therefore consider that the proposed heat network does not yield an economically viable scheme in its current configuration. The Applicant is committed to exploring project delivery models and financial mechanisms to realise a scheme, through active engagement with key network stakeholders.

10.5.3 It may be possible to secure funding under the HNIP to improve the economic case. It is anticipated that grants and loans will be made available to both public and private sector applicants, with first applications expected in Q3 2018. The economic feasibility of the scheme should be reassessed in the future when there is more certainty over heat loads and in light of any developments to the subsidy landscape.

10.5.4 The draft Development Consent Order submitted with the application (**Document Reference 3.1**) incorporates a requirement in Schedule 2 that requires the Applicant to monitor and review the potential for CHP and to report the findings to LBB.

## 10.6 Energy Efficiency Measures

10.6.1 In order to qualify as high-efficiency cogeneration as defined in the Energy Efficiency Directive (EED), the scheme must achieve at least 10% savings in primary energy usage compared to the separate generation of heat and power. The proposed DH network would result in primary energy savings (PES) of 30.0%.

10.6.2 To be considered 'Good Quality' CHP under the Combined Heat and Power Quality Assurance (CHPQA) scheme, the quantity of heat exported must be sufficient to achieve a Quality Index (QI) of at least 100, or the safeguard

provisions must be met. Based on the projected annual average export, the proposed scheme would result in a QI score of 104.7. The scheme therefore represents BAT for energy efficiency and environmental performance through the application of CHP, as defined by CHPQA.

10.6.3 The actual energy efficiency performance of the scheme will be dependent on the nature of the new-build developments in Thamesmead. Continuing engagement with the local developer and local planning authorities (LBB, RBG) and the GLA is pivotal to realise the scheme. The Applicant intends to enter into a commercial agreement as development proposals are established and the costs and benefits are clear.

10.6.4 Given the quantity of low carbon energy available from REP, which could be utilised to offset fossil fuel consumption, we consider that the Proposed Development represents best environmental practice and would support fully with GLA's objectives, as well as the local Bexley Energy Masterplan.

## Appendix A Modelled Residual Waste Composition for CIF Assessment

Material component	Carbon %	Biogenic Carbon (%)	Fossil Carbon (%)	Net CV (MJ/kg)
Paper/Card	31.27%	100%	0%	10.749
Non-recyclable paper	28.69%	100%	0%	9.735
Dense plastic	54.76%	0%	100%	24.682
Plastic film	48.11%	0%	100%	21.279
Textiles	39.86%	50%	50%	14.327
Misc. Combustible	39.48%	60%	40%	14.612
Misc. Non Combustible	6.99%	42%	58%	2.573
Glass	0.31%	100%	0%	1.414
Ferrous Metal	0.00%	0%	100%	0.000
Non-ferrous metal	0.00%	0%	100%	0.000
Kitchen Organics	13.46%	100%	0%	3.460
Garden Organics	17.17%	100%	0%	4.210
Electrical / electronic equipment	15.81%	0%	100%	7.060
Potentially Hazardous	20.37%	3%	97%	0.000
Fines	13.75%	100%	0%	3.479

Data source:	WRATE Carbon Content	WRATE V2	WRATE V2	WRATE CV
--------------	----------------------	----------	----------	----------

<b>CV of MSW</b>	<b>8.64</b>	<b>MJ/kg</b>
<b>Carbon content of MSW</b>	<b>24.16</b>	<b>% of MSW</b>
<b>Biogenic carbon content of MSW</b>	<b>15.94</b>	<b>% of MSW</b>
<b>Fossil carbon content of MSW</b>	<b>8.22</b>	<b>% of MSW</b>

**Appendix B Illustrative Site Layout**

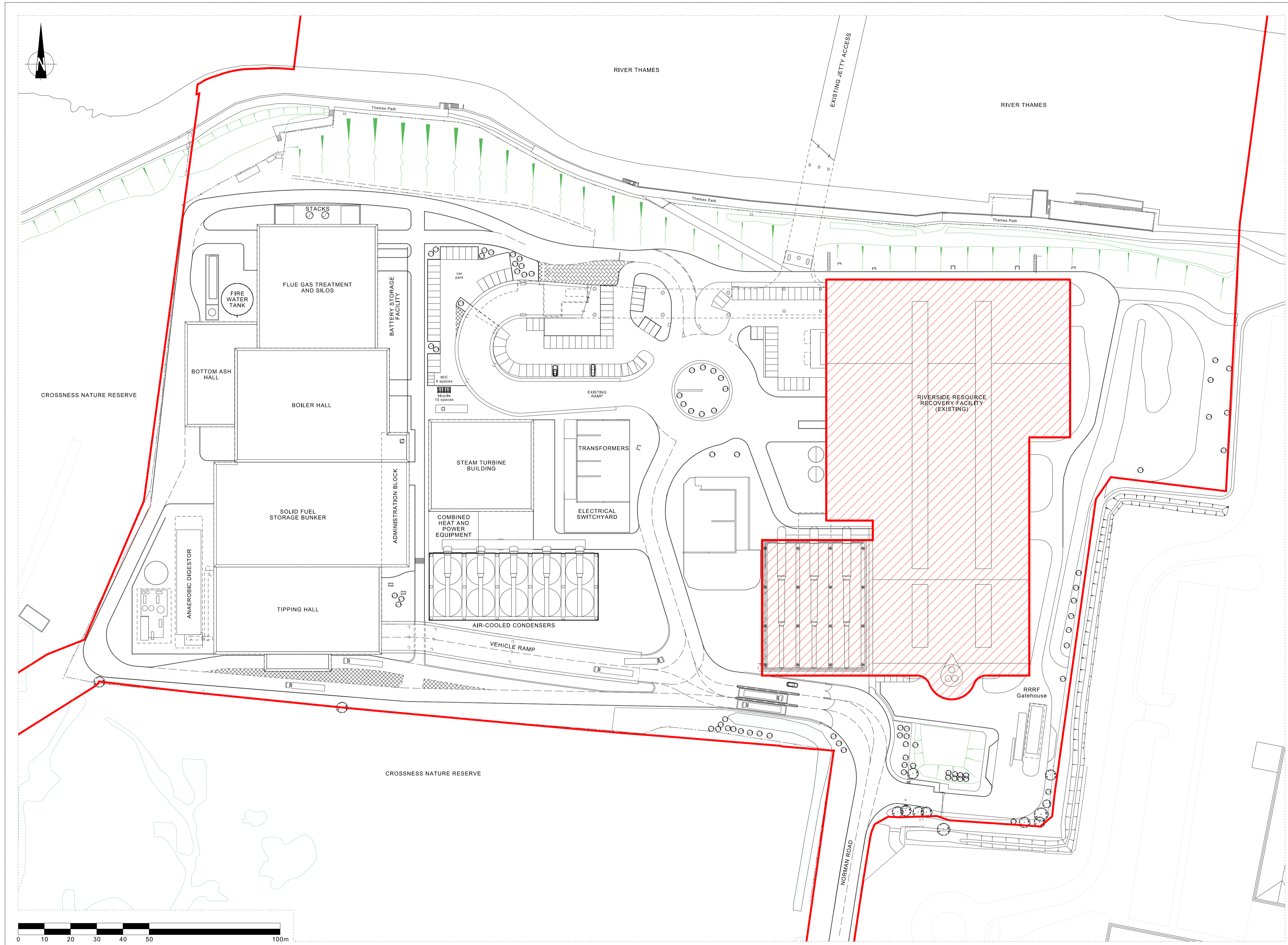

KEY:

— ORDER LIMITS

▨ AREA NOT INCLUDED IN DEVELOPMENT CONSENT ORDER

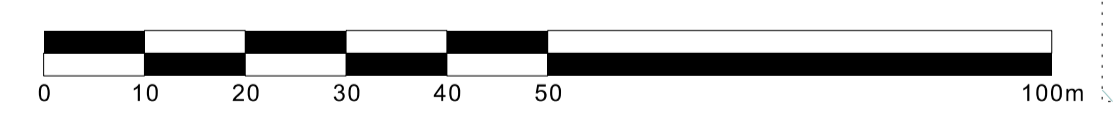

**WEEDON**  
architects

Harry's Yard  
176-178 Newhall St  
Birmingham B3 1SJ  
www.weedonarchitects.co.uk

T: 0121 454 4171  
F: 0121 455 9152

© Weedon Architects LLP

**CORY**  
RIVERSIDE ENERGY

RIVERSIDE ENERGY PARK  
 NORMAN ROAD BELVEDERE LONDON  
 DOC REF 2.4 ILLUSTRATIVE SITE LAYOUT PLAN  
 THE RIVERSIDE ENERGY PARK SITE LONDON  
 REGULATION 5(2)(o)

Date	31.10.18
A1 Scale	1:750
Drawn by	AG
Checked by	PC
Drawing Number	DOC REF 2.4

**Appendix C    Indicative ERF Heat and Mass  
Balance**

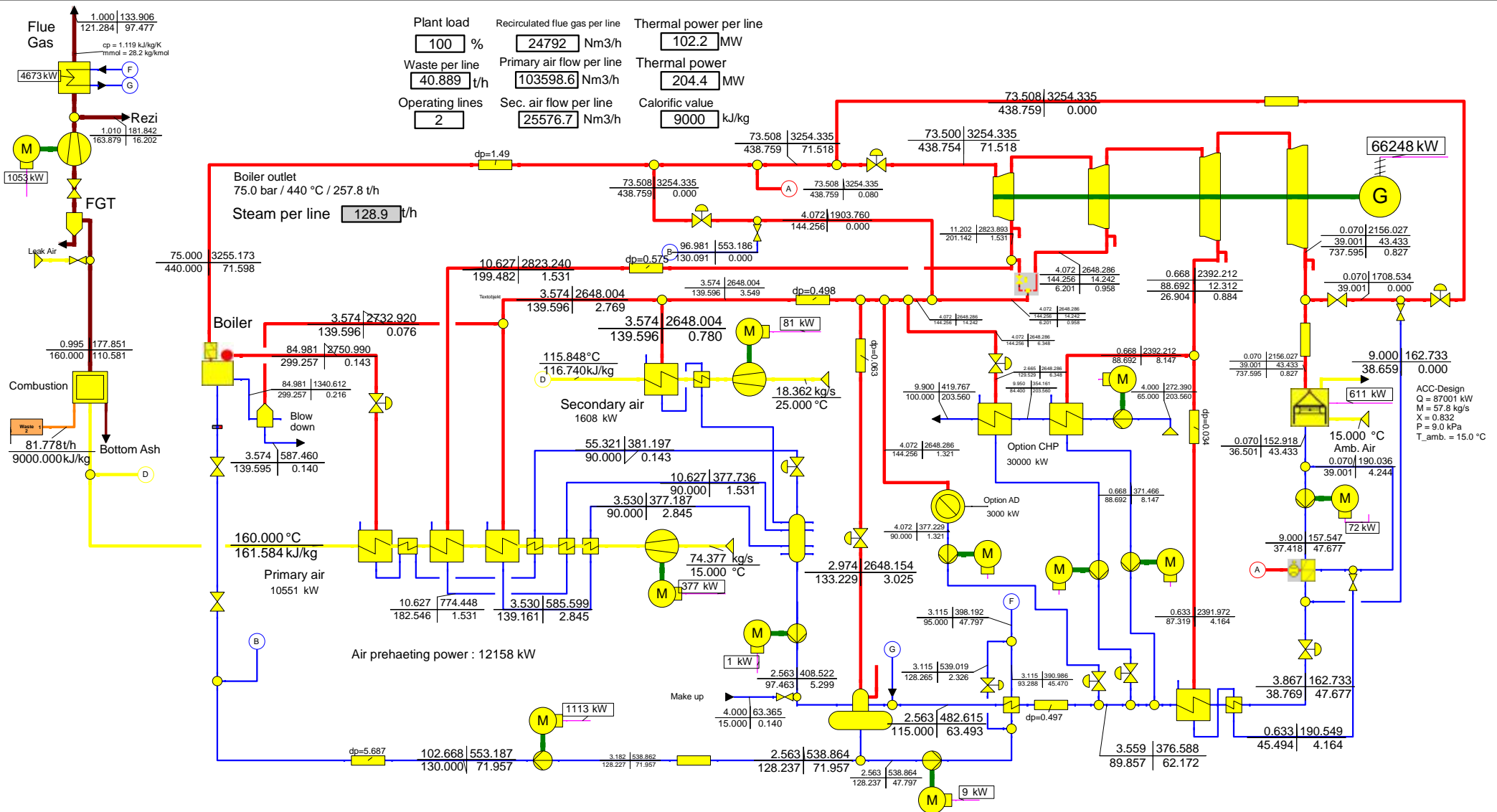

			OPTION:	<b>HEAT AND MASS BALANCE WATER STEAM CYCLE</b>	
			Combustion diagram Load Point	Design Case (Profile)	
0.2	Turbine efficiency adapted, FG-Cond Preh Power	14.03.2018	LP N	LC5c_CHP_30MW_AD	P bar   H kJ/kg T °C   M kg/s VM m <sup>3</sup> /s   X -
0.1	CHP and HX for AD implemented	12.02.2018	Project	Design Case Description	pressure = absolute
0	First Issue	11.12.2018	<b>YE-3362</b>	<b>Nominal Operation with CHP and AD</b>	
Rev.	Revision Description	Date	Name	Document No:	Customer Document No:

## Appendix D Potential Existing Heat Consumers

Site	Use	Post code	Estimated heat demand (MWh / annum)
Iron Mountain	Digital information and asset storage	DA17 6JY	1,701
Wernick Hire	Modular building manufacturer / portable building hire	DA17 6JY	5,119
Asda	Chilled distribution centre	DA17 6JY	942
Asda	Cross dock centre	DA17 6JY	2,429
Asda	Recycling Centre	DA17 6BG	1,651
Jablite	Expanded polystyrene products manufacturer	DA17 6BG	1,650
Amazon	Distribution centre	DA17 6AS	922
London City Roast	Coffee roasters	DA17 6AX	2,947
Lidl	Distribution centre	DA17 6BS	2,895
Belvedere Industrial Estate	Industrial estate	DA17 6BS	1,006
Performance Chemicals	Cleaning and maintenance chemical supplier	DA17 6BS	604
Tarmac (Mulberry)	Construction materials supplier (asphalt and concrete)	DA17 6BS	28
Thames Steel Services	Steel fabricator	DA17 6BS	3,099
D&X London	E-commerce distribution centre	DA17 6AN	1,162
FM Conway	Construction contractor	DA17 6AN	184
CMT Group	Construction equipment supplier	DA17 6AN	222



Riverside Energy Park  
Riverside Energy Park CHP Study

---

Concorde Metals	Scrap yard	DA17 6AZ	108
CCF	Insulation and interior building product supplier	DA17 6AS	187
GPM Hire & Supplies	Construction products and equipment supplier	DA17 6AS	65
Display Developments Limited	Thermoplastic products fabricator	DA17 6AS	385
Tuffnells Parcels Express	Distribution centre	DA17 6BT	113
HTC Van Centre	Commercial vehicle storage	DA17 6BT	148
River Wharf Business Park	Various warehouses	DA17 6AR	926
Belvedere Warehousing & Distribution	Distribution centre	DA17 6AN	452
Gilray Plant Ltd	Scaffolding supplier	DA8 1DE	225
Tarmac (Erith Wharf)	Construction materials supplier (aggregates)	DA8 1DE	9
Hanson UK	Construction materials supplier	DA8 1DE	194
Tesco	Dot Com Distribution Centre	DA8 1DE	870
Archer Daniels Midland	Rapeseed oil refinery	DA8 1DL	213,204
Oyo Business Units	Warehouse units	DA17 6AX	317
Ocado	Distribution Centre	DA8 1DF	3,954
Edible Oils	Seed oil bottling site	DA8 1DL	2,110
Olleco (London East)	Food waste collection depot	DA8 1EW	391
Neville UK	Catering equipment supplier	DA8 1EW	204
Buildbase	Building materials supplier	DA8 1EW	32

Riverside Energy Park  
Riverside Energy Park CHP Study

---

Unknown	Unknown	DA8 1EW	110
HMRC	Storage Depot	DA8 1EW	307
Select Plant Hire	Construction equipment supplier depot	DA8 1DG	98
Unknown	Unknown	DA8 1EX	176
WT Henley	Electrical distribution equipment manufacturer	DA8 1EX	1,077
Saint-Gobain (British Gypsum)	Training centre	DA8 1DE	36
Stanmore Contractors Ltd	Drywall and façade subcontractor	DA8 1DE	91
KnowHow	Electrical goods repair and storage	DA8 1EX	1,561
Landor Cartons Ltd	Packaging manufacturer	DA8 1NP	672
Home Move Box	Gift box supplier	DA18 4AP	102
Howdens Joinery	Building materials supplier	DA18 4AP	58
Europa Worldwide Logistics	Transport and logistics provider	DA18 4AU	271
Intersped Logistics (UK) Ltd	Transport and logistics provider	DA18 4AA	249
Halvey Engineering	Vehicle maintenance and repair	DA18 4AP	318
Finesse Colour Ltd	Printing service	DA18 4AP	49
Brew Bros Fabrications Ltd	Steel fabricator	DA18 4AP	330
Kent Precision Tooling	Plastic products manufacturer	DA18 4AA	341
Seropa Ltd	Catering equipment manufacturer	DA18 4AA	342
Freshasia Food Ltd	Food producer	DA18 4AA	338

Riverside Energy Park  
Riverside Energy Park CHP Study

---

Ferndale Foods Ltd	Food producer	DA18 4AR	297
Begg & Co Thermoplastics Ltd	Thermoplastic products fabricator	DA18 4AW	313
Smart Freight Solutions Ltd	Transport and logistics provider	DA18 4AA	188
Citipost Ltd	Distribution service	DA18 4AA	181
Unknown	Unknown	DA18 4AA	350
Booker Retail Partners	Food wholesaler	DA18 4AG	1,886
Thames Innovation Centre	Business centre	DA18 4AL	109
British Loose Leaf	Stationary manufacturer	DA18 4AL	546
Horizon Business Centre	Industrial business park	DA18 4AJ	1,057
Kencot Close Business Park	Industrial business park	DA18 4AB	992
Würth	Assembly materials wholesaler	DA18 4AE	551
Anchor Bay Construction Products Ltd	Building materials supplier	DA18 4AF	101
Forsite Construction Accessories Ltd	Building materials supplier	DA18 4AF	102
Allied Hygiene Systems Ltd	Cleaning wipe manufacturer	DA18 4AF	1,876
The Morgan	Restaurant	DA17 6FD	656
Snap Fitness Belvedere	Gym	DA17 6FD	379
Capital Industrial Estate	Industrial Estate	DA17 6BJ	9,805
Cross Quarter	Retail Park	SE2 9NU	455
Thamesmere Leisure Centre	Leisure Centre	SE28 8RE	1,712

Riverside Energy Park  
Riverside Energy Park CHP Study

---

Cannon Retail Park / Thamesmead Shopping Centre	Retail Park	SE28 8RD	347
Birchmere Business Park	Industrial business park	SE28 0AF	479
White Hart Triangle	Industrial Estate	SE28 0GU	2,428
West Thamesmead Business Park	Industrial business park	SE28 0AB	766
Ash Poultry Wholesalers Ltd	Meat wholesaler	SE28 0GU	714
HMP Belmarsh	Prison	SE28 0EB	683
HMP Thameside	Prison	SE28 0DF	5,832
Belmarsh Magistrates' Court	Courthouse	SE28 0HA	1,516

**Appendix E    Location of Potential Heat Consumers**

PROPOSED DEVELOPMENTS	
1	THAMESMEAD WATERFRONT
2	LAND AT BINSEY WALK
3	SOUTHMEER VILLAGE
4	LAND AT CORALINE WALK
5	LAND AT SEDGEMERE ROAD
6	THE REACH
7	WEST THAMESMEAD GATEWAY
EXISTING DEVELOPMENTS	
8	IRON MOUNTAIN
9	WERNICK HIRE
10	ASDA CHILLED DISTRIBUTION CENTRE
11	ASDA CROSS DOCK CENTRE
12	ASDA RECYLING CENTRE
13	JABLITE
14	AMAZON DISTRIBUTION CENTRE
15	LONDON CITY ROAST
16	LIDL DISTRIBUTION CENTRE
17	BELVEDERE INDUSTRIAL ESTATE
18	PERFORMANCE CHEMICALS
19	TARMAC (MULBERRY)
20	THAMES STEEL SERVICES
21	D&X LONDON
22	FM CONWAY
23	CMT GROUP
24	CONCORDE METALS
25	CCF, INSULATION AND INTERIOR BUILDING PRODUCTS
26	GMP HIRE & SUPPLIES
27	DISPLAY DEVELOPMENTS LIMITED
28	TUFFNELLS PARCELS EXPRESS
29	HTC VAN CENTRE
30	RIVER WHARF BUSINESS PARK
31	BELVEDERE WAREHOUSING & DISTRIBUTION
32	GILRAY PLANT LTD
33	TARMAC (ERITH WHARF)
34	HANSON UK
35	TESCO DOT COM DISTRIBUTION CENTRE
36	ARCHER DANIELS MIDLAND
37	OYO BUSINESS UNITS
38	OCADO DISTRIBUTION CENTRE
39	EDIBLE OILS
40	OLLECO (LONDON EAST)
41	NEVILLE UK
42	BUILDBASE
43	UNKNOWN
44	HMRC STORAGE DEPOT
45	SELECT PLANT HIRE
46	UNKNOWN
47	WT HENLEY
48	SAINT-GOBAIN (BRITISH GYPSUM)
49	STANMORE CONTRACTORS LTD
50	KNOWHOW
51	LANDOR CARTONS LTD
52	HOME MOVE BOX
53	HOWDENS JOINERY
54	EUROPA WORLDWIDE LOGISTICS
55	INTERSPED LOGISTICS (UK) LTD
56	HALVEY ENGINEERING
57	FINESSE COLOUR LTD
58	BREW BROS FABRICATIONS LTD
59	KENT PRECISION TOOLING
60	SEROPA LTD
61	FRESHASIA FOOD LTD
62	FERNDALE FOODS LTD
63	BEGG & CO THERMOPLASTICS LTD
64	SMART FREIGHT SOLUTIONS LTD
65	CITIPOST LTD
66	UNKNOWN
67	BOOKER RETAIL PARTNERS
68	THAMES INNOVATION CENTRE
69	BRITISH LOOSE LEAF
70	HORIZON BUSINESS CENTRE
71	KENCOT CLOSE BUSINESS PARK
72	WÜRTH
73	ANCHOR BAY CONSTRUCTION PRODUCTS LTD
74	FORSITE CONSTRUCTION ACCESSORIES LTD
75	ALLIED HYGIENE SYSTEMS LTD
76	THE MORGAN
77	SNAP FITNESS BELVEDERE
78	CAPITOL INDUSTRIAL ESTATE
79	CROSS QUARTER
80	THAMESMERE LEISURE CENTRE
81	CANNON RETAIL PARK/THAMESMEAD SHOPPING CENTRE
82	BIRCHMERE BUSINESS PARK
83	WHITE HART TRIANGLE
84	WEST THAMESMEAD BUSINESS PARK
85	ASH POULTRY WHOLESALERS LTD
86	BELMARSH MAGISTRATES COURT
87	HMP BELMARSH
88	HMP THAMESIDE



ALL INFORMATION ON THIS DRAWING IS INDICATIVE ONLY, AND MAY BE SUBJECT TO FURTHER DESIGN DEVELOPMENT.

DO NOT SCALE

NOTES:

R1	PRELIMINARY	AO	RLB	28.03.18
REV.	DETAILS OF REVISION	DRAWN	CHKD	DATE

**FICHTNER**  
CONSULTING ENGINEERS LIMITED  
Kingsgate, Wellington Road North,  
Stockport, Cheshire, SK4 1LW, UK  
Tel: 0161 476 0032  
Website: www.fichtner.co.uk

CLIENT: CORY RIVERSIDE ENERGY

SITE: RIVERSIDE ENERGY PARK

PROJECT: CHP STUDY

TITLE: POTENTIAL HEAT CONSUMERS

DRAWING STATUS:	PRELIMINARY	
DRAWN BY:	AO	DATE: 15.03.18
CHECKED BY:	RLB	DATE: 15.03.18
FILENAME:	2383-002-R1.DWG	
OFFICE OF ISSUE:	STOCKPORT	
SHEET SIZE:	A2	SCALE: NTS
DRAWING No.:	2383-002	REVISION: R1
	Sheet 1 of 1	

**Appendix F    Indicative Pipe Route**

PROPOSED DEVELOPMENTS	
1	THAMESMEAD WATERFRONT
2	LAND AT BINSEY WALK
3	SOUTHMERE VILLAGE
4	LAND AT CORALINE WALK
5	LAND AT SEDGEMERE ROAD
7	WEST THAMESMEAD GATEWAY

ALL INFORMATION ON THIS DRAWING IS INDICATIVE ONLY, AND MAY BE SUBJECT TO FURTHER DESIGN DEVELOPMENT.

DO NOT SCALE

NOTES:



R1	PRELIMINARY	AO	RLB	29.03.18
REV.	DETAILS OF REVISION	DRAWN	CHKD	DATE



**FICHTNER**  
CONSULTING ENGINEERS LIMITED  
Kingsgate, Wellington Road North,  
Stockport, Cheshire, SK4 1LW, UK  
Tel: 0161 476 0032  
Website: www.fichtner.co.uk

CLIENT:	CORY RIVERSIDE ENERGY
SITE:	RIVERSIDE ENERGY PARK
PROJECT:	CHP STUDY
TITLE:	INDICATIVE PIPE ROUTE

DRAWING STATUS:	PRELIMINARY	
DRAWN BY:	AO	DATE: 28.03.18
CHECKED BY:	RLB	DATE: 28.03.18
FILENAME:	2383-003-R1.DWG	
OFFICE OF ISSUE:	STOCKPORT	
SHEET SIZE:	A3	SCALE: NTS
DRAWING No.:	<b>2383-003</b>	REVISION: <b>R1</b>
	Sheet 1 of 1	



**Appendix G Cost-Benefit Assessment Inputs and Key Outputs**

Scenario Choice (dropdown box)

1

Power generator (Heat Source) same fuel amount

Technical solution features

- Heat carrying medium (hot water, steam or other) (dropdown box)
- Total length of supply pipework (kms)
- Peak heat demand from Heat User(s) (MWth)
- Annual quantity of heat supplied from the Heat Source(s) to Heat User(s) (MWh)

DCF Model Parameters

- Discount rate (pre-tax pre-financing) (%) - 17% suggested rate
- Project lifespan (yrs)
- Exceptional shorter lifespan (yrs)

Cost and revenue streams

Construction costs and build up of operating costs and revenues during construction phase

Project asset lifespan (yrs)

Exceptional reason for shorter lifespan of Heat Supply Infrastructure, Standby Boiler and/ or Heat Station (yrs)

Construction length before system operational and at steady state (yrs)

Number of years to build

Year 1 costs (£m) and build up of operating costs and revenues (%)

Year 2 costs (£m) and build up of operating costs and revenues (%)

Year 3 costs (£m) and build up of operating costs and revenues (%)

Year 4 costs (£m) and build up of operating costs and revenues (%)

Year 5 costs (£m) and build up of operating costs and revenues (%)

Non-power related operations

OPEX for full steady state Heat Supply Infrastructure on price basis of first year of operations (partial or steady state) (£m)

OPEX for full steady state Heat Station on price basis of first year of operations (partial or steady state) (£m)

OPEX for full steady state Standby Boilers on price basis of first year of operations (partial or steady state) (£m)

OPEX for full steady state Industrial CHP on price basis of first year of operations (partial or steady state) (£m) \*

Additional equivalent OPEX to pay for a major Industrial CHP overall spread over the life of the asset (£m) on price basis of first year of operations (partial or steady state) (£m) \*

Other 1 - Participant to define (£m)

Other 2 - Participant to define (£m)

Total non-power related operations

Annual inflation for all non-power related OPEX from first year of operations (full or partial) (%)

Unit Energy Prices, Energy Balance, Fuel Related Operational costs and Revenue Stream

Heat sale price (£/ MWh) at first year of operations (partial or full)

Annual quantity of heat supplied from the Heat Source(s) to Heat User(s) at steady state (MWh)

Equivalent heat sales if first year of operations is steady state (£ m)

Heat sale price inflation from first year of operations (full or partial) (% per year)

Percentage of heat supplied by Standby Boiler (if relevant)

'Lost' electricity sale price (£/ MWh) at first year of operations

Z-ratio (commonly in the range 3.5 - 8.5)

Power generation lost at steady state (MWh)

Equivalent 'lost' revenue from power generation if first year of operations is steady state (£ m)

Electricity sale price inflation from first year of operations (full or partial) (% per year)

Industrial CHP electricity sale price (£/ MWh) at first year of operations (full or partial)

Industrial CHP electrical generation in steady state (MWh)

Equivalent revenue from power generation if first year of operations is steady state (£ m)

Industrial CHP electricity price inflation from first year of operations (full or partial) (% per year)

Fuel price for larger power generator/ CHP at first year of operations (full or partial) (£ / MWh)

Z-ratio (commonly in the range 3.5 - 8.5)

Power efficiency in cogeneration mode (%)

Additional fuel required per year for larger power generator / CHP in steady state (MWh)

Equivalent additional fuel costs if first year of operations is steady state (£ m)

Fuel price inflation from first year of operations (full or partial) (% per year)

Fuel price for Standby Boiler at first year of operations (£ / MWh)

Boiler efficiency of Standby Boiler (%)

Additional fuel required per year for Standby Boiler in steady state (MWh)

Equivalent additional fuel costs if first year of operations is steady state (£m)

Fuel price inflation for Standby Boiler from first year of operations (full or partial) (% per year)

Heat purchase price (£/ MWh) at first year of operations (partial or full)

Annual quantity of heat supplied from the Heat Source(s) to Heat User(s) at steady state (MWh)

Equivalent cost of heat purchased if first year of operations is steady state (£ m)

Heat purchase price inflation from first year of operations (full or partial) (% per year)

Fuel price (£ / MWh) at first year of operations (partial or full)

Boiler efficiency of district heating plant

Fuel avoided per year in steady state (MWh)

Equivalent fuel savings if first year of operations is steady state (£m)

Fuel price inflation from first year of operations (full or partial) (% per year)

Fiscal benefits (£m) in first year of operations assuming it is at steady state \*\*

Fiscal benefits inflation rate from first year of operations (full or partial) (%) \*\*

\* In the case of Industrial CHP a separate model template is available for typical indicative CAPEX, non-power related OPEX, additional equivalent OPEX to pay for a major overall, MWh of electricity generated in the steady state and the additional fuel required.

\*\* Operator only needs to enter a value for fiscal benefits (£m) and the annual fiscal benefit inflation rate (%) if the NPV without fiscal benefits is negative at the specified discount rate

Hot water	2	Participant to define
8.239	30	Regulatory prescribed
Lines 49 & 79	2	Calculated
17%	30	Prescribed - but possibility to change if make a case
	0	

% operating costs and revenues during construction phase	Heat Supply Infrastructure - used in Scenarios 1, 2, 3 and 5	Heat Station - used in Scenarios 1, 2 and 3	Standby boilers (only if needed for Scenarios 1, 2 and 3)	Industrial CHP - used in Scenario 4
	30	30	30	

% (ONLY IF APPLICABLE)	£m	£m	£m	£m
0%	6.027186	1.175576	1.580592	
0%	6.027186	1.175576	1.580592	

0.2
0.2
0.1
0.4
2.0%

Scenario used	1	2	3	4	5
	Power generator (Heat Source) same fuel amount	Power generator (Heat Source) same electrical output	Industrial installation (Heat Source) - use waste heat	Industrial installation (Heat Source) - CHP set to thermal input	District heating (Heat User)

12.00	12.00				
114,385	114,385				
1.4					
2.0%	2.0%				
9%	9%				
52.30	52.30				
10.00	10.00				
10,446	10,446				
0.55					
2.0%	2.0%				
0.00					
0					
0.00					
0.0%					
0.00					
0					
0					
0		#DIV/0!			
0.00					
0.0%					
40.00	40.00				
80%	80%	80%	80%		
12,405	12,405				
0.50					
2.00%	2.0%				
0.00					
0					
0.0					
0.0%					
0.00					
0					
0					
0.0					
0.0%					4.0%
0.00	0.00				
0.0%					

OUTPUTS

Nominal Project IRR (before financing and tax) over 32 years

Nominal NPV (before financing and tax) (£m) over 32 years

#NUM!

-14.07

**Appendix H    CHP-Ready Application**

# CHP-R Assessment Form

#	Description	Units	Notes / Instructions
<b>Requirement 1: Plant, Plant Location and Potential Heat Loads</b>			
1.1	Plant Name		Riverside Energy Park (REP) Energy Recovery Facility (ERF)
1.2	Plant Description		<p>REP will comprise an integrated range of technologies including: waste energy recovery, anaerobic digestion, solar panels and battery storage.</p> <p>The REP ERF is designed to process approximately 655,000 tonnes of C&amp;I or MSW per annum, with an assumed NCV of 9 MJ/kg.</p> <p>The REP ERF will have two waste incineration lines, waste reception, waste storage, water, fuel gas and air supply systems, boilers, steam-turbine-generator, facilities for the treatment of exhaust gases, on-site facilities for treatment and storage of residues and waste water, flues, stack, systems for controlling incineration operations, recording and monitoring conditions.</p> <p>Residual waste will be combusted on a moving grate to ensure continuous mixing of the fuel and hence promote good combustion. The heat released by the combustion of the fuel is recovered in a water tube boiler, which is integral to the furnace and will produce (in combination with superheaters) high pressure superheated steam. The steam from the boiler will feed a steam-turbine generator used to generate electricity. Exhaust steam will be cooled using an air-cooled condenser.</p> <p>The principal elements of REP comprise complementary energy generating development, with an electrical output of up to 96 MWe. The turbine design has been selected to allow for up to 30 MW of heat to be available for export to a district heating network.</p>

1.3	Plant Location (Postcode / Grid Ref)	<p>The REP application site comprises approximately 7 hectares of land located approximately at National Grid Reference (NGR) TQ 49467 80680, accessed off Norman Road, Belvedere, London DA17 6JY in the LBB, immediately to the west of the existing Riverside Resource Recovery Facility (RRRF), operated by Cory. A site layout is provided in Appendix B of the CHP Study.</p>
1.4	Factors Influencing Selection of Plant Location	<p>The REP site is predominantly used by the Applicant as an ancillary area for the existing RRRF located at the same address as outlined above. The REP site includes the existing jetty in the River Thames which is currently used for delivery of waste and despatch of by-products at the existing RRRF. The jetty will be used for the same purpose for the operation of REP and there is capacity to accommodate the additional throughputs.</p> <p>The site is served by good transport links via access from the River Thames (for waste delivery and residue offtake as detailed above) and Norman Road, a single carriageway road linking to the dual carriageway A2016 Picardy Manor Way. Heat is rejected from the steam cycle via an air cooled condenser so proximity to a cooling water source was not of consequence to site selection.</p> <p>The development site is located within a Heat Network Priority Area, as set out London Plan.</p>

1.5	Operation of Plant		
a)	Proposed Operational Plant Load	%	100.0
b)	Thermal Input at Proposed Operational Plant Load	MW	204.4
c)	Net Electrical Output at Proposed Operational Plant Load	MW	63.9
d)	Net Electrical Efficiency at Proposed Operational Plant Load	%	31.2
e)	Maximum Plant Load	%	100.0
f)	Thermal Input at Maximum Plant Load	MW	204.4
g)	Net Electrical Output at Maximum Plant Load	MW	63.9
h)	Net Electrical Efficiency at Maximum Plant Load	%	31.2

i)	Minimum Stable Plant Load	%	70.0
j)	Thermal Input at Minimum Stable Plant Load	MW	143.1
k)	Net Electrical Output at Minimum Stable Plant Load	MW	42.9
l)	Net Electrical Efficiency at Minimum Stable Plant Load	%	30.0
1.6	Identified Potential Heat Loads		
			<p>A review of the potential heat demand within a 10 km radius of REP has been undertaken in accordance with the requirements set out in Section 4 of the EA's CHP Ready Guidance.</p> <p>Seven prospective residential (up to 20,000 dwellings) and commercial developments have been identified to the west of the REP site in Thamesmead. Connection to these consumers represents the most favourable configuration for a low temperature heat network and is projected to deliver a heat demand of 114,385 MWh/annum. Additional capacity could potentially be added to the network by connecting existing developments in the town of Woolwich / West Thamesmead, which is located along the proposed DH pipeline corridor.</p> <p>Of the four existing large heat consumers identified (using the BEIS UK CHP Development Map) only Archer Daniels Midland, a rapeseed oil refinery, is located on the south bank of the River Thames and could therefore present a connection prospect. This potential consumer may offer an anchor load for future connections to businesses in the locality. However, the heat demand requirements of individual businesses, and whether the REP ERF could supply the heat grade required, is unknown.</p> <p>Further details can be found in Section 6 of the CHP Study.</p>

<b>1.7 Selected Heat Load(s)</b>			
a)	Category (e.g. Industrial / District Heating)		District heating
b)	Maximum Heat Load Extraction Required	MW	30.9 MW
<b>1.8 Export and Return Requirements of Heat Load</b>			
a)	Description of Heat Load Extraction		Saturated steam via turbine extractions at approximately 4.1 bar(a) and 0.7 bar(a).
b)	Description of Heat Load Profile		Variable heat load. A detailed heat load profile can be found in Section 6.6 of the CHP Study.
c)	Export Pressure	bar a	9.9 (subject to district heating piping system design)
d)	Export Temperature	°C	100.0 (subject to consumer heat system design)
e)	Export Flow	t/h	754.6 (peak)
f)	Return Pressure	bar a	4.0 (subject to district heating piping system design)
g)	Return Temperature	°C	65.0 (subject to consumer heat system design)
h)	Return Flow	t/h	754.6 (peak)
<b>Requirement 2: Identification of CHP Envelope</b>			
2.0	Comparative Efficiency of a Standalone Boiler for supplying the Heat Load	% LHV	90
<b>2.1 Heat Extraction at 100% Plant Load</b>			
a)	Maximum Heat Load Extraction at 100% Plant Load	MW	30.0 (to district heating)
b)	Maximum Heat Extraction Export Flow at 100% Plant Load	t/h	732.8
c)	CHP Mode Net Electrical Output at 100% Plant Load	MW	60.9
d)	CHP Mode Net Electrical Efficiency at 100% Plant Load	%	29.8
e)	CHP Mode Net CHP Efficiency at 100% Plant Load	%	44.5
f)	Reduction in Primary Energy Usage for CHP Mode at 100% Plant Load	%	33.1
<b>2.2 Heat Extraction at Minimum Stable Plant Load</b>			



a)	Maximum Heat Load Extraction at Minimum Stable Plant Load	MW	14.1
b)	Maximum Heat Extraction Export Flow at Minimum Stable Plant Load	t/h	344.4
c)	CHP Mode Net Electrical Output at Minimum Stable Plant Load	MW	41.5
d)	CHP Mode Net Electrical Efficiency at Minimum Stable Plant Load	%	29.0
e)	CHP Mode Net CHP Efficiency at Minimum Stable Plant Load	%	38.8
f)	Reduction in Primary Energy Usage for CHP Mode at Minimum Stable Plant Load	%	31.2
2.3	Can the Plant supply the Selected Identified Potential Heat Load (i.e. is the Identified Potential Heat Load within the 'CHP Envelope')?		The identified potential peak heat load is projected to exceed the maximum plant export capacity by 0.9 MW. There are a number of uncertainties regarding the heat demand profile, so this is not considered a material concern at this stage. It is envisaged that thermal stores, peak lopping plant or additional heat capacity (from the RRRF) could be made available to supply peak loads if required.
<b>Requirement 3: Operation of the Plant with the Selected Identified Heat Load</b>			
3.1	Proposed Operation of Plant with CHP		
a)	CHP Mode Net Electrical Output at Proposed Operational Plant Load	MW	62.8
b)	CHP Mode Net Electrical Efficiency at Proposed Operational Plant Load	%	30.7
c)	CHP Mode Net CHP Efficiency at Proposed Operational Plant Load	%	36.0
d)	Reduction in Net Electrical Output for CHP Mode at Proposed Operational Plant Load	MW	1.1
e)	Reduction in Net Electrical Efficiency for CHP Mode at Proposed Operational Plant Load	%	0.5
f)	Reduction in Primary Energy Usage for CHP Mode at Proposed Operational Plant Load	%	29.3

g)	Z Ratio		8.0
<b>Requirement 4: Technical Provisions and Space Requirements</b>			
4.1	Description of Likely Suitable Extraction Points		Steam for the district heating system could be supplied via two controlled steam flow extractions from intermediate and low pressure turbine bleeds. Heat would be transferred to a closed hot water circuit for offsite export via a series of condensing heat exchangers.
4.2	Description of Potential Options which could be incorporated in the Plant, should a CHP Opportunity be realised outside the 'CHP Envelope'		On the basis that the projected average heat load is 10.9 MW and the plant is capable of exporting up to 30 MW offsite, the CHP opportunity lies within the CHP envelope.
4.3	Description of how the future Costs and Burdens associated with supplying the Identified Heat Load / Potential CHP Opportunity have been minimised through the implementation of an appropriate CHP-R design		<p>The Applicant has engaged with a preferred technology provider, HZI, to progress design and provide supporting information for the DCO application and EP. HZI has undertaken outline design of the development and prepared an illustrative masterplan which includes a CHP plant room located adjacent to the turbine hall to facilitate steam and condensate interfaces.</p> <p>The turbine design has been selected to maximise electrical efficiency while ensuring heat export can be delivered with high levels of efficiency. This is in line with the EA CHP Ready Guidance which states that the initial electrical efficiency of a CHP-R plant (before any opportunities for the supply of heat are realised) should be no less than that of the equivalent non-CHP-R plant.</p>
4.4	Provision of Site Layout of the Plant, indicating Available Space which could be made available for CHP-R		Please refer to the Layout drawing provided in Appendix B of the CHP Study. The CHP plant room would contain all of the main heat supply system equipment including heat exchangers, steam and condensate piping, circulation pumps, expansion vessel, water treatment plant and associated components. The CHP plant room is sized to house equipment required to deliver the maximum heat export capacity from the REP ERF and if required, the RRRF.

### Requirement 5: Integration of CHP and Carbon Capture

5.1	Is the Plant required to be CCR?		No
5.2	Export and Return Requirements Identified for Carbon Capture		
	100% Plant Load		
a)	Heat Load Extraction for Carbon Capture at 100% Plant Load	MW	N/A
b)	Description of Heat Export (e.g. Steam / Hot Water)		N/A
c)	Export Pressure	bar a	N/A
d)	Export Temperature	°C	N/A
e)	Export Flow	t/h	N/A
f)	Return Pressure	bar a	N/A
g)	Return Temperature	°C	N/A
h)	Return Flow	t/h	N/A
i)	Likely Suitable Extraction Points		N/A
	Minimum Stable Plant Load		
j)	Heat Load Extraction for Carbon Capture at Minimum Stable Plant Load	MW	N/A

k)	Description of Heat Export (e.g. Steam / Hot Water)		N/A
l)	Export Pressure	bar a	N/A
m)	Export Temperature	°C	N/A
n)	Export Flow	t/h	N/A
o)	Return Pressure	bar a	N/A
p)	Return Temperature	°C	N/A
q)	Return Flow	t/h	N/A
r)	Likely Suitable Extraction Points		N/A
5.3	Operation of Plant with Carbon Capture (without CHP)		
a)	Maximum Plant Load with Carbon Capture	%	N/A
b)	Carbon Capture Mode Thermal Input at Maximum Plant Load	MW	N/A
c)	Carbon Capture Mode Net Electrical Output at Maximum Plant Load	MW	N/A
d)	Carbon Capture Mode Net Electrical Efficiency at Maximum Plant Load	%	N/A
e)	Minimum Stable Plant Load with CCS	%	N/A
f)	Carbon Capture Mode CCS Thermal Input at Minimum Stable Plant Load	MW	N/A
g)	Carbon Capture Mode Net Electrical Output at Minimum Stable Plant Load	MW	N/A
h)	Carbon Capture Mode Net Electrical Efficiency at Minimum Stable Plant Load	%	N/A
5.4	Heat Extraction for CHP at 100% Plant Load with Carbon Capture		
a)	Maximum Heat Load Extraction at 100% Plant Load with Carbon Capture [H]	MW	N/A
b)	Maximum Heat Extraction Export Flow at 100% Plant Load with Carbon Capture	t/h	N/A
c)	Carbon Capture and CHP Mode Net Electrical Output at 100% Plant Load	MW	N/A
d)	Carbon Capture and CHP Mode Net Electrical Efficiency at 100% Plant Load	%	N/A

e)	Carbon Capture and CHP Mode Net CHP Efficiency at 100% Plant Load	%	N/A
f)	Reduction in Primary Energy Usage for Carbon Capture and CHP Mode at 100% Plant Load	%	N/A
<b>5.5</b>			
Heat Extraction at Minimum Stable Plant Load with Carbon Capture			
a)	Maximum Heat Load Extraction at Minimum Stable Plant Load with Carbon Capture	MW	N/A
b)	Maximum Heat Extraction Export Flow at Minimum Stable Plant Load with Carbon Capture	t/h	N/A
c)	Carbon Capture and CHP Mode Net Electrical Output at Minimum Stable Plant Load	MW	N/A
d)	Carbon Capture and CHP Mode Net Electrical Efficiency at Minimum Stable Plant Load	%	N/A
e)	Carbon Capture and CHP Mode Net CHP Efficiency at Minimum Stable Plant Load	%	N/A
f)	Reduction in Primary Energy Usage for Carbon Capture and CHP Mode at Minimum Stable Plant Load	%	N/A
<b>5.6</b>			
Can the Plant with Carbon Capture supply the Selected Identified Potential Heat Load (i.e. is the Identified Potential Heat Load within the 'CHP and Carbon Capture Envelope')?			
<b>5.7</b>			
Description of Potential Options which could be incorporated in the Plant for useful integration of any realised CHP System and Carbon Capture System			
<b>Requirement 6: Economics of CHP-R</b>			

6.1	Economic Assessment of CHP-R		In order to assess the commercial feasibility of the CHP scheme a cost benefit assessment was undertaken in accordance with EA's Article 14 guidance, as required under the Energy Efficiency Directive. Details of the cost benefit assessment are presented in Section 7 the CHP Study.
<b>BAT Assessment</b>			
	Is the new plant a CHP plant at the outset (i.e. are there economically viable CHP opportunities at the outset)?		Yes, subject to securing funding through the Heat Network Investment Project (HNIP) and/or the Heat Networks Delivery Unit (HNDU) via London Borough of Bexley. On this basis, the Applicant intends to install all heat supply infrastructure to its site boundary and continue engagement with stakeholders to deliver a renewable and low carbon decentralised energy scheme.
	If not, is the new plant a CHP-R plant at the outset?		N/A
	Once the new plant is CHP-R, is it BAT?		N/A